

SMR

ALWAYS THE BEST OPTION

SMR SYSTEM

SURGICAL TECHNIQUE

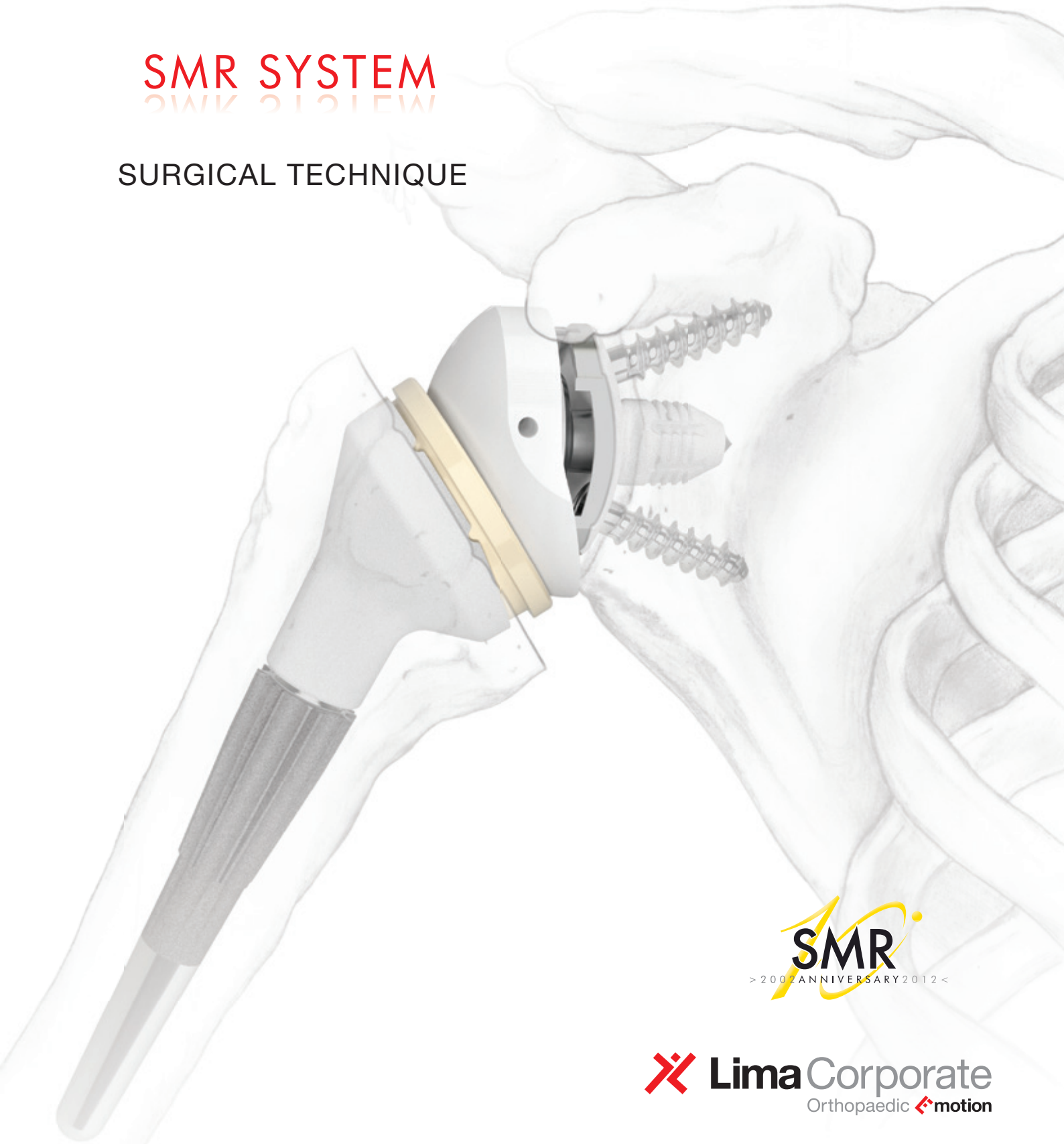

 **Lima Corporate**
Orthopaedic  motion



SMR PRIMARY SURGICAL TECHNIQUE

Index

Indications, contraindications and warnings	pag. >> 6
Introduction	pag. >> 9
Clinical cases	pag. >> 13
SMR PRIMARY SURGICAL TECHNIQUE	
SMR Trauma	pag. >> 14
SMR Elective Anatomical - Humeral Part	pag. >> 20
SMR Glenoid	pag. >> 27
SMR Reverse	pag. >> 32
SMR CTA Head	pag. >> 44
INSTRUMENT SET	pag. >> 48
PRODUCT CODES	pag. >> 54

LEONARDO DA VINCI: the Vitruvian Man. Studies of human proportions (1490)

SMR

ALWAYS THE BEST OPTION



A modular system...

THE MODULARITY OF THE SYSTEM ALLOWS:

- ▶ **Simple conversions:**
revisions to reverse of a previous anatomical implant can be executed without removing the stem and the Metal Back glenoid.
- ▶ **Intraoperative flexibility:**
the appropriate implant for the patient's needs can be built through a step by step assembly process, regardless of the pathology encountered.
- ▶ **More efficiency in the operating room,**
thanks to the reduced instrumentation required by a single platform system.

On the anatomical side, the SMR Metal Back glenoid has proven

“that metal-backed cementless implants can still be considered for glenoid replacement and that the results obtained are no worse than those with the cemented all-polyethylene glenoid.”^[3]

In a biomechanical study about the stability of the SMR Metal Back in reverse configuration,

“The greatest baseplate micromotion (26.83µm) was well within the accepted limit for osseous ingrowth into uncemented prosthesis.”^[4]

In fact, “The study demonstrates promising mid-term results with SMR Reverse 44mm X-UHMWPE and 36mm eccentric CoCrMo glenospheres allowing a significant improvement of clinical outcomes, thanks to the inversion of the materials and the eccentric design, with even faster and more stable functional recovery with 44mm Glenospheres.”^[5]





[1, 2, 3, 4, 5]

...with proven performance

10 YEARS OF CLINICAL EXPERIENCE

The clinically proven SMR modular shoulder system evolves with the pathology, allowing the surgeon to choose the most appropriate solution in resurfacing, fracture hemi, total shoulder, reverse shoulder or revision surgeries.

BIBLIOGRAPHY

- [1] De Biase C.F., Gumina S., Borroni M., Castagna A., Postacchini F. Shoulder glenoid revision to reverse implant: clinical and radiological results using a modular system. Proceedings of the Annual Meeting of the American Academy of Orthopaedic Surgeons (AAOS); Feb 7-11, 2012; San Francisco, California (USA)
- [2] Young S.W., Everts N.M., Ball C.M., Astley T.M., Poon P.C. The SMR reverse shoulder prosthesis in the treatment of cuff-deficient shoulder conditions. J Shoulder Elbow Surg, 18(4): 622-626, 2009
- [3] Castagna A., Randelli M., Garofalo R., Maradei L., Giardella A., Borroni M. Mid-Term results of a metalbacked glenoid component in total shoulder replacement. J Bone Joint Surg [Br], 92(10): 1410-1415, 2010
- [4] Poon P.C., Chou J., Young D., Malak S. F., Anderson I.A. Biomechanical evaluation of different designs of glenospheres in the SMR reverse shoulder prosthesis: micromotion of the baseplate and risk of loosening. Shoulder & Elbow, 2: 94- 99, 2010
- [5] Castagna A., Bloch H.R., Bishof A., Budassi P., Agneskirchner J.D., Borroni M., Domenghini C., Frattini M., Zoni S. Comparison of clinical outcomes of reverse shoulder arthroplasty with glenospheres of different designs, diameters and materials. J Orthopaed Traumatol 2011; 12 suppl 1; S32



SMR PRIMARY SURGICAL TECHNIQUE

Indications, contraindications and warnings

▼ INDICATIONS

The SMR Shoulder System is intended for partial or total, primary or revision shoulder joint replacement.

The SMR Anatomic Shoulder System is indicated for partial or total, primary or revision shoulder joint replacement in patients suffering from disability due to:

- non-inflammatory degenerative joint disease including osteoarthritis and avascular necrosis;
- inflammatory degenerative joint disease such as rheumatoid arthritis;
- treatment of acute fractures of the humeral head that cannot be treated with other fracture fixation methods;
- revision of a failed primary implant;
- cuff tear arthropathy (CTA Heads only);

The Large Resection Stems are indicated for oncology applications.

The SMR Reverse Shoulder System is indicated for primary, fracture or revision total shoulder replacement in a grossly rotator cuff deficient joint with severe arthropathy (disabled shoulder).

The patient's joint must be anatomically and structurally suited to receive the selected implants and a functional deltoid muscle is necessary to use the device.

The Modular SMR Shoulder System allows the assembly of components in various humeral and glenoid constructs. The constructs are intended for cemented and uncemented use as specified in the following table.

In the Anatomic shoulder the humeral construct consists of the humeral stem, the humeral body, the adaptor taper and the humeral head.

In the Reverse shoulder the humeral construct consists of the humeral stem, the reverse humeral body and the reverse liner. On the humeral side the fixation of the humeral stem determines if the construct is cemented or uncemented.

The Anatomic glenoid construct consists of an all polyethylene glenoid or a metal back assembled with a liner while the Reverse glenoid construct consists of the metal back, the connector and the glenosphere. On the glenoid side, the fixation of the all polyethylene glenoid or the metal back determines if the construct is cemented or uncemented.

SMR PRIMARY SURGICAL TECHNIQUE

Indications, contraindications and warnings

System		Components	Material	Use	
Anatomic	Reverse			Cem	Not Cem
•	•	SMR Stems (Cemented, Cemented Revision)	Ti6Al4V	X	
•	•	SMR Stems (Cementless Finned, Cementless Revision)	Ti6Al4V		X
•	•	SMR Large Resection stems	Ti6Al4V	X	
•	•	SMR Modular Augments	Ti6Al4V	X	
•		SMR Humeral Bodies (Trauma, Finned)	Ti6Al4V	X	X
	•	SMR Reverse Humeral Body	Ti6Al4V	X	X
	•	SMR Reverse HA Coated Humeral Body	Ti6Al4V+HA		X
•		SMR Humeral Heads (Standard, CTA)	CoCrMo	X	X
			Ti6Al4V	X	X
•		SMR Adaptor Tapers (Neutral, Eccentric)	Ti6Al4V	X	X
•	•	SMR CTA Head Adaptor for Reverse Humeral Body	Ti6Al4V	X	X
	•	SMR Glenospheres	CoCrMo		X
			Ti6Al4V		X
			UHMWPE X-Lima +Ti6Al4V		X
	•	SMR Connectors	Ti6Al4V		X
	•	Reverse Liners	UHMWPE X-Lima	X	X
			CoCrMo	X	X
			Alumina	X	X
•		SMR Cemented Glenoids	UHMWPE	X	
•		SMR 3 Pegs Cemented Glenoids	UHMWPE X-Lima	X	
•	•	SMR Metal Back Glenoids	Ti6Al4V+PorTi+HA		X
•		SMR Metal Back Liner	UHMWPE		X
•	•	SMR Bone screws	Ti6Al4V		X
	•	SMR Glenoid Plates	Ti		X
Material Standards					
Ti6Al4V (ISO 5832-3 - ASTM F1472) - CoCrMo (ISO 5832-12 - ASTM F1537) – Ti (ASTM F67) - UHMWPE (ISO 5834-2 - ASTM F648) Alumina (ISO 6474) – PorTi Titanium Coating (ASTM F1580) – HA Hydroxyapatite Coating (ISO 13779)					



SMR PRIMARY SURGICAL TECHNIQUE

Indications, contraindications and warnings

▼ WARNINGS

In selecting patients for surgery, the following factors can be critical to the eventual success of the procedure:

- **Partial Shoulder replacement:** in cases with a deficient and unreconstructable rotator cuff, a CTA-head is indicated;
- **Total Shoulder replacement:** the rotator cuff must be intact or reconstructable. In cases with a deficient and unreconstructable rotator cuff, a hemiprosthesis with a CTA head or a Reverse Total Shoulder Arthroplasty is indicated.
- **Reverse Shoulder replacement:** the bone stock of the glenoid and humerus must be able to support the implant. In cases with significant bone loss and in which adequate fixation on the glenoid side cannot be obtained, a hemiarthroplasty with a CTA-head should be performed.

Note. With CTA heads the use of Trauma Humeral Bodies is recommended to avoid possible impingement between the head and the body when using the Finned Humeral Body and the eccentric tapers in the lower position.

Note. The size Large metal back is not suitable for coupling with 36 mm and 40 mm glenospheres.

▼ CONTRAINDICATIONS

Absolute contraindications include

1. local or systemic infection;
2. septicaemia;
3. persistent acute or chronic osteomyelitis;
4. confirmed nerve lesion compromising shoulder joint function;
5. deltoid muscle insufficiency.

Relative contraindications include:

- vascular or nerve diseases affecting the concerned limb
- poor bone stock (for example due to osteoporosis or extended previous revision surgery) compromising the stability of the implant;
- metabolic disorders which may impair fixation and stability of the implant;
- any concomitant disease and dependence that might affect the implanted prosthesis;
- metal hypersensitivity to implant materials.

In cases of bone tumors, use an appropriate system designed to treat cases requiring large bone resections (SMR Large Resections stems). The use of primary or revision implants not designed and intended for use in cases of bone resection may result in a poor outcome and / or failure of the implant or implant fixation.

▼ RISK FACTORS

The following risk factors may result in poor results with this prosthesis:

- overweight;
- strenuous physical activities (active sports, heavy physical work);
- fretting of modular junctions;
- incorrect implant positioning;
- muscle deficiencies;
- multiple joint disabilities;
- refusal to modify postoperative physical activities;
- patient history of infections or falls;
- systemic diseases and metabolic disorders;
- local or disseminated neoplastic diseases
- drug therapies that adversely affect bone quality, healing, or resistance to infection
- drug use or alcoholism;
- marked osteoporosis or osteomalacia;
- patient's resistance to disease generally weakened (HIV, tumour, infections);
- severe deformity leading to impaired anchorage or improper positioning of implants.

▼ PREOPERATIVE PLANNING

Standard X-rays are used to assist with planning of the operation. It is recommended to use a normal ap-view in internal and external rotation as well as an axillary view, Bernageau or Morrison view.

In a fracture case it is recommended to use a CT-Scan with three-dimensional reconstruction.

If required an MRI can be used for clear examination of the extent of the bone deficit and to see the muscle/capsule quality.

In cases of osteoarthritis and osteonecrosis a magnetic resonance exam has to be taken to clearly evaluate the bone deficiency and the quality of the muscle and the capsule.

In post-traumatic cases, such as in special cases of disabled shoulder, a neurological exam is helpful for decision making. Templates are used in all osteoarthritic cases; they can also be used in fracture cases but often in a limited mode, depending on the type of fracture.

The x-ray templates provided for SMR have a 105% scale; digital templates are available as well.

▼ ANAESTHESIA

Shoulder surgery is one of the areas in which an understanding of the surgery and participation by the anaesthesiologist is especially important for the outcome of the surgery. This applies to accurate preoperative evaluation of the patient as well as intra op techniques.

They should have a good understanding of positioning on the operating table and postoperative pain management.

Shoulder prosthetic replacement can be performed with regional (scalenus) anaesthesia combined with sedation and/or with general anaesthesia.

The modern technique of interscalenic block was introduced by Winnie in 1970 and soon became the standard for

anaesthesia and postoperative pain management in shoulder surgery.

Requested surgical positioning (beach chair position) must be accurately followed by the anaesthetic staff to avoid hypotension and consecutive brain hypoperfusion.

Postoperative analgesia is important and can be performed by IV continuous, single injection or on demand application of analgesics. Patient-controlled analgesia (PCA) is recommended.

▼ POSITIONING

Shoulder arthroplasty is normally performed in a “beach-chair” position; the surgeon needs complete access to the shoulder joint. The arm is free or stabilized by arm-holders. The shoulder must be positioned off the edge of the table to afford unobstructed arm extension.

The patient’s head must be supported and stabilized in the neutral position. Nerve injury due to brachial plexus traction during positioning and surgery must be avoided.

If possible, one assistant stays behind the shoulder, the second on the opposite side of the patient, so the surgeon has a complete anterior view of the shoulder and can move the joint without any obstacle.

SMR PRIMARY SURGICAL TECHNIQUE

Introduction

▼ ACCESS

We recommend two types of surgical approach to the shoulder joint. As in every surgical procedure, the access depends not only on diagnosis and planned surgical treatment but also on the experience of the surgeon.

Ranges of glenohumeral motion are evaluated with the patient under anaesthesia to confirm the preoperative assessment and the extent of capsular release needed to restore ROM postoperatively.

DELTO-PECTORAL APPROACH

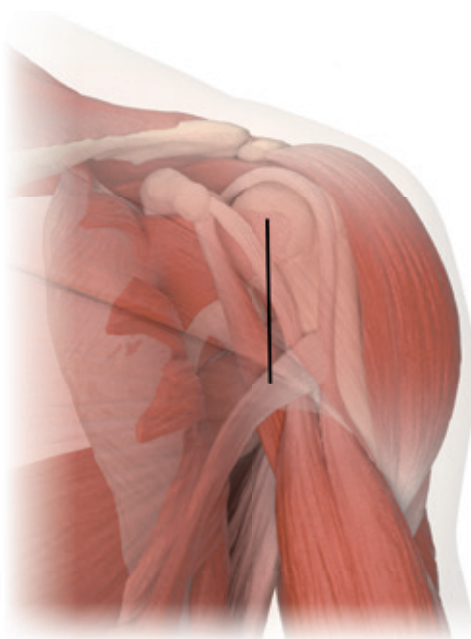

Anterior vertical incision, starting 1 cm laterally of the coracoid bone, slanting towards the axillary's pouch.

If there is a metaphysal fracture, slanting laterally towards the deltoid insertion at the humerus.

The cephalic vein is dissected and the deltopectoral interval is developed, retracting the deltoid and the cephalic vein laterally.

The clavipectoral fascia is incised along the lateral edge of the conjoined tendon up to the coracoacromial ligament. With the clavipectoral fascia incised, a retractor can easily be placed over the superolateral aspect of the humeral head to retract the deltoid.

The conjoined tendon is retracted medially.

The musculocutaneous nerve penetrates the lateral coracobrachialis muscle between 3 and 8 cm distal to the tip of the coracoid process. The position of the axillary nerve should be identified along the anterior surface of the subscapularis muscle, deep to the conjoined tendon. The axillary nerve crosses the inferolateral border of the subscapularis 3 to 5 mm medial to its musculotendinous junction and has an intimate anatomic relation with the inferior capsule of the shoulder joint.

The anterior humeral circumflex artery and veins are visualized, ligated and divided.

The subscapularis tendon is released, divided 1 cm medial to its attachment or with some bone chip of the lesser tuberosity. Separate the subscapularis from the capsule and incision of the capsule is performed to the inferior border of the glenoid rim, protecting the axillary nerve with a blunt retractor. Release of the subscapularis and 270° capsular release.

Closure: Accurate reconstruction of the minor and major tubercle by suture, bone anchors or (hemiarthroplasty, resurfacing, tsa) cerclage.

If the long head of the biceps tendon is intact, reconstruct also the biceps groove to avoid impingement. Closure of delto-pectoral groove.

LATERAL (DELTOID SPLITTING) APPROACH

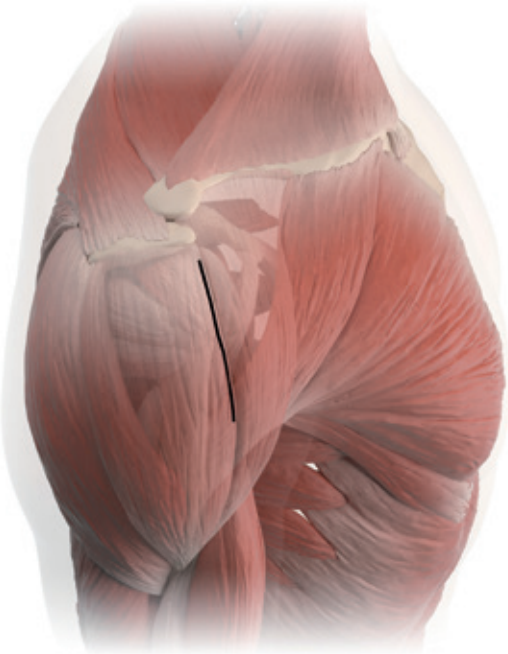

Begin the incision at the anterolateral tip of the acromion and carry it distally over the deltoid muscle about 5 cm. Define the tendinous interval 4 to 5 cm long between the anterior and middle thirds of the deltoid; splitting the muscle here provides an avascular approach to underlying structures.

Incise the thin wall of the subdeltoid bursa and explore the rotator cuff as desired by rotating and abducting the arm to bring different parts of it into view in the floor of the wound.

CASE I ▼

GENDER: male

AGE: 72 years old

PATHOLOGY: cuff tear arthropathy (CTA)



Pre-operative



Post-operative

CASE II ▼

GENDER: male

AGE: 76 years old

PATHOLOGY: cuff tear arthropathy



Pre-operative

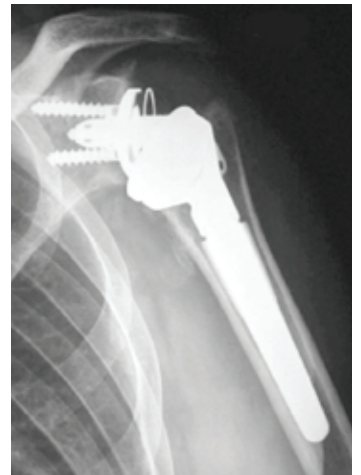

Post-operative

CASE III ▼

GENDER: female

AGE: 65 years old

PATHOLOGY: arthrosis



Pre-operative

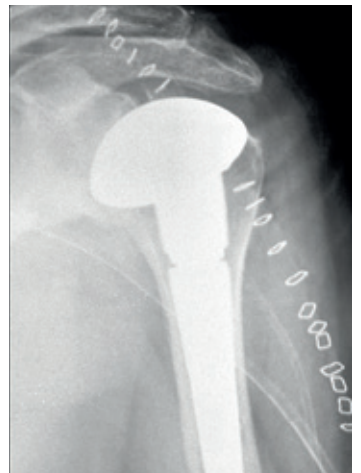

Post-operative

SMR PRIMARY SURGICAL TECHNIQUE

SMR Trauma



figure 1



figure 2

▼ PRELIMINARY PHASES

Prosthetic treatment of acute traumas is generally limited to complex fractures-dislocations: fractures in 3-4 fragments, dislocation fractures of the humeral head, compression fractures with over 50% of the articular surface being damaged, etc.

ACCESS

The SMR prosthesis can be implanted with one of the usual approaches:

- delto-pectoral
- deltoid split

Each approach has advantages and disadvantages, the choice of the approach is left to the surgeon. The operating technique described here below is independent of the chosen approach.

FRACTURE FRAGMENT REMOVAL

It is recommended to identify distally the tendon of the long head of the biceps muscle, to then follow it proximally up to the rotator cuff interval: the greater tuberosity will be localised laterally to the bicipital groove; the lesser tuberosity medially. These fragments are carefully preserved with the tendons of the rotator cuff inserted. Once the shoulder joint has been entered, the not useful fragments are removed, including the humeral head. If the arm is extended and rotated outwards, the diaphyseal stump can be clearly seen.

▼ PREPARATION OF THE HUMERAL CANAL

Screw the *trial stem* (B1) with the planned diameter in the preoperative plan onto *impactor* (C1) (figure 1) and tap the stem into the canal (figure 2A).

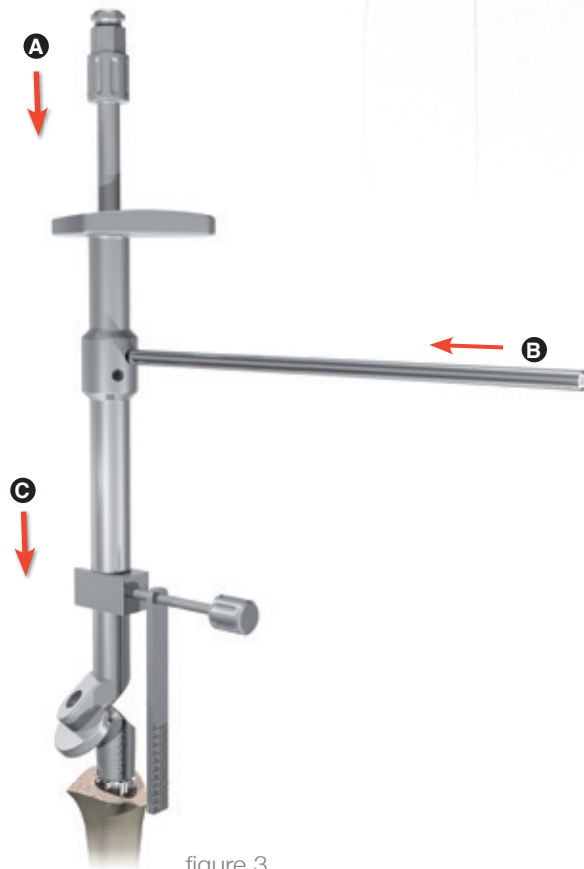

figure 3

Check the press-fit inside the canal by pulling the impactor handle and, if necessary, replace the stem with the next size up. Insert the *centimetre gauge* (S2) in its seat on the impactor handle (figure 2B) and taking a specific point on the humeral stump, check the measurement indicated by the gauge.

Once the correct stem diameter has been determined and the indicated measurement has been noted, remove the gauge and proceed with the next surgical step.

Apply a Medium, Long or Short *trial humeral body* (G2) to the selected stem and tighten the locking screw using the *allen wrench* (L2). Place the trial implant on the *prosthesis introducer* (A2) and fasten it by tightening the proximal screw (figure 3A).

Before inserting the assembly into the canal, insert the *alignment rod* (O2) into the *prosthesis introducer* (A2) (figure 3B) and with the arm flexed at 90°, position the rod so that it is parallel with the forearm. In this position the implant will have a 30° retroversion.

If a smaller retroversion angle is required, the rod should be externally rotated by an angle of choice. Insert the stem in the canal (figure 3C) and copy the height of the previously measured implant.

SMR PRIMARY SURGICAL TECHNIQUE

SMR Trauma

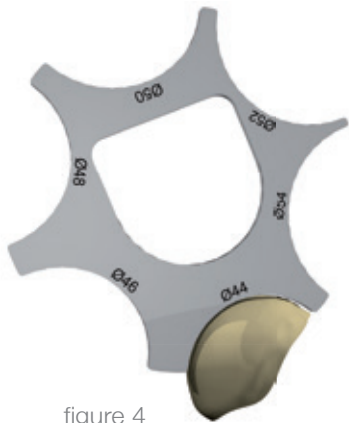

figure 4

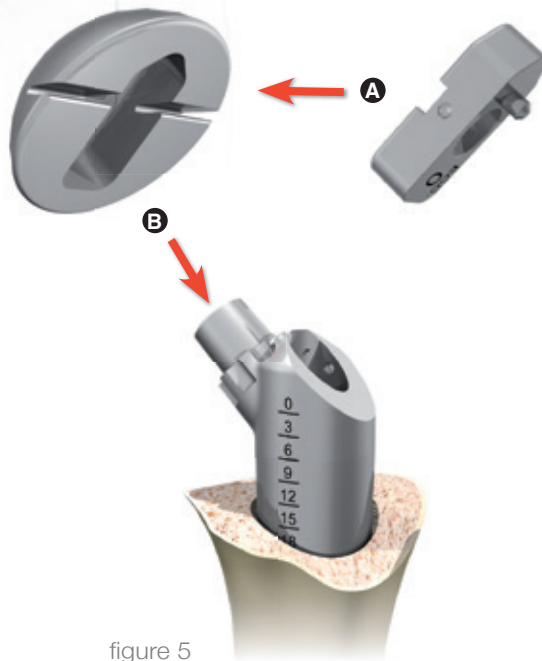

figure 5



figure 6

▼ TRIAL ADAPTORS AND HUMERAL HEADS

The head diameter is determined using the *head gauge* (D2) (figure 4). Insert the *STD neutral trial adaptor* (E2) into the *trial humeral head* (C2) and fit the head to the taper of the trial humeral body (figure 5-6).

Reduce the shoulder and check the match with the glenoid. If it is not well aligned with the glenoid cavity, substitute the neutral adaptor with an eccentric one. Make up for any ligamentous laxity by using a Long adaptor.

If an eccentric adaptor is used, mark the position of the head with diathermy using the arrow as a reference.

This procedure helps to place the final head in the correct position. If there is no humeral landmark near the head, memorise the last adaptor peg seat in the trial humeral

body. The final head peg should be inserted in the same seat again.

Caution! During this step, the head is not press fitted to the neck of the humeral body, therefore when performing a trial reduction, make sure that the head does not uncouple.

Before removing all the trial components, if the position of the humeral body has been modified, mark the new retroversion using diathermy corresponding to one of the markers on the impactor and note the depth of the body in the canal. Remove all trial components.

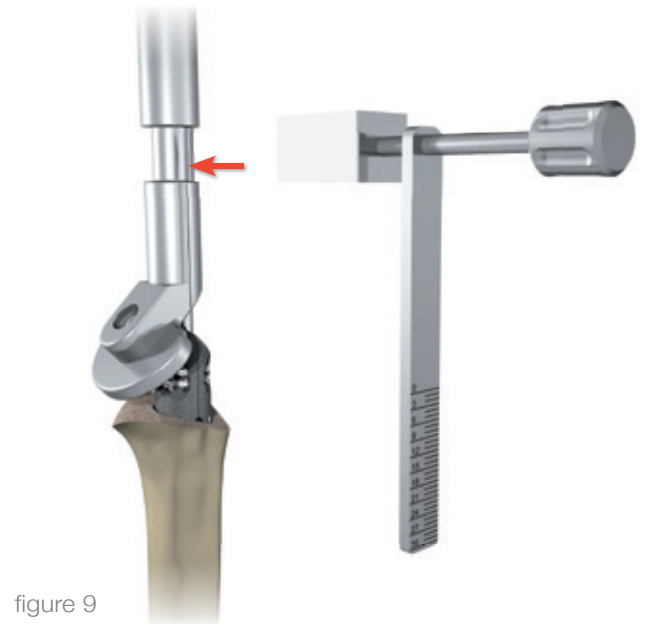
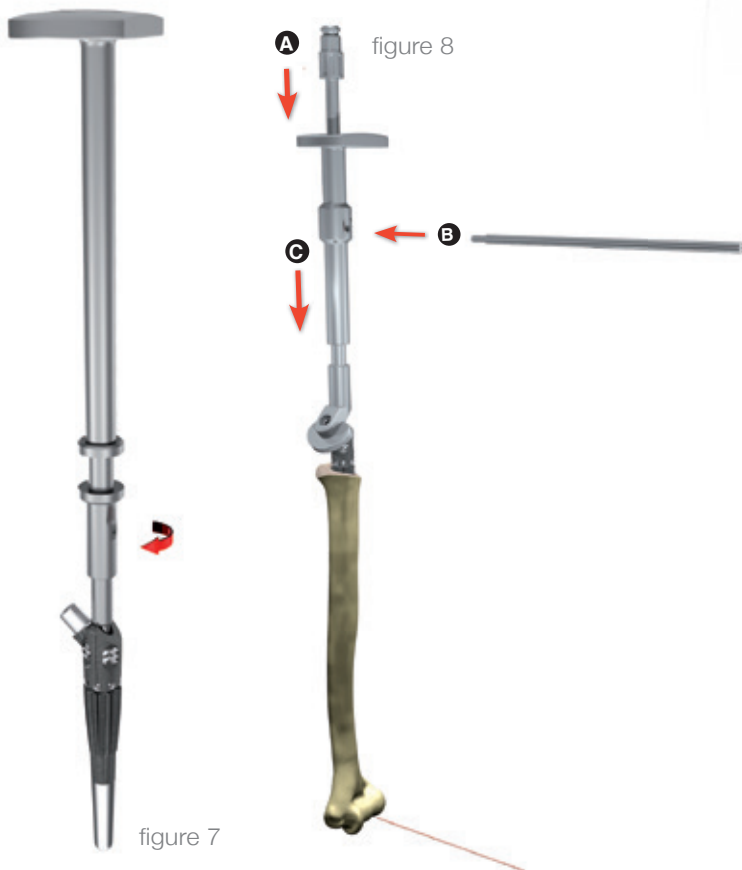

▼ INSERTION OF THE FINNED STEM

The final finned stem is the same size as the last trial stem used. Also take the trauma humeral body in the height required.

INSERTION OF THE STEM AND FINAL BODY

Assemble the final humeral body on the finned stem. If the *stem impactor (C1)* is screwed in with force, it will engage the morse taper (figure 7). Remove the impactor and tighten the safety screw.

Assemble the implant complete with *prosthesis introducer (A2)*, tightening the proximal screw to lock the system (figure 8A). Before inserting the implant, insert the alignment rod into the introducer handle (figure 8B) and repeat the

alignment procedure with the forearm in such a way that the retroversion angle can be obtained.

Tap the implant into the canal (figure 8C) and stop when the centimetre gauge has reached the required depth in relation to the reference point that had been previously chosen on the humeral stump (figure 9); loosen the proximal screw and remove the introducer.

SMR PRIMARY SURGICAL TECHNIQUE

SMR Trauma

figure 10

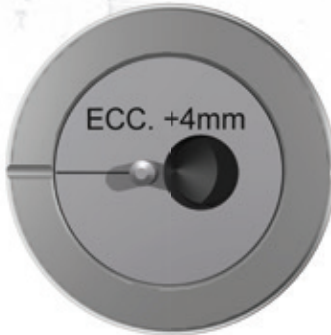
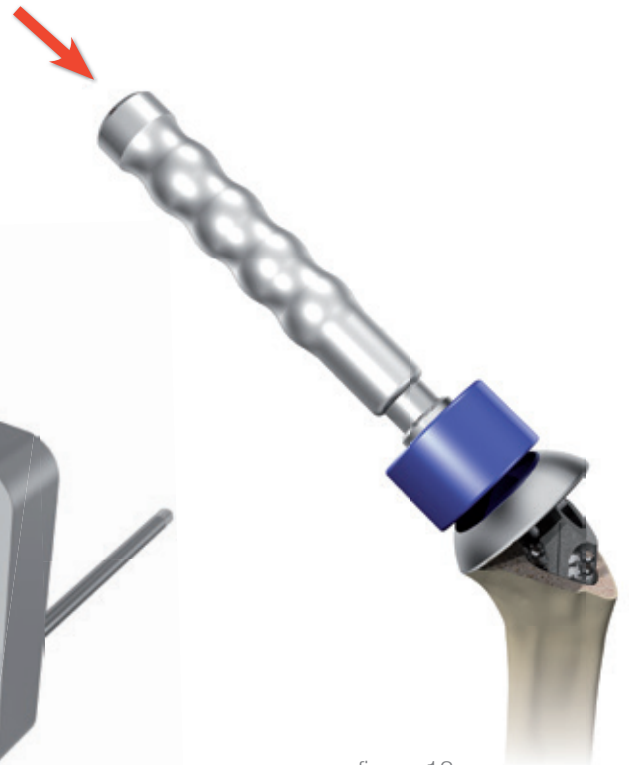

figure 11



figure 12



▼ APPLICATION OF THE ADAPTOR TAPER TO THE HUMERAL HEAD

Remove the appropriate adaptor taper and final head from the sterile packaging.

Apply the adaptor taper to the head. If an eccentric adaptor taper is used, insert it by aligning the marking with that of the humeral head (figure 10). The concentric adaptor taper has no such markings.

Position the system in the *humeral head press (R2)* (figure 11) and tighten. In this way the head and the adaptor taper will be press fitted together while applying an opposite force with the *alignment rod (O2)*.

▼ INSERTION OF THE HUMERAL HEAD

Apply the humeral head to the humeral body chosen inserting the adaptor taper peg in the same position as the trial component.

Make sure that the contact surfaces are perfectly clean and that the head or adaptor does not contact the bone, as this could compromise the stability of the Morse taper coupling. Lastly, secure the taper coupling by tapping gently with the *humeral head impactor (Q2)* (figure 12).



figure 13

▼ REDUCTION AND SUTURE

The humerus is reduced by means of gentle traction and internal rotation.

The capsule is not sutured to avoid stiffness and restriction. Accurate reconstruction of the tuberosities around the humeral body and reinsertion of the subscapularis muscle, by trans-osseous stitches to the lesser tuberosity, is performed.

The use of suction drainage is recommended.

▼ CEMENTED STEM

If cemented stems are used, the operating technique has a few variations. Proceed as described previously, replacing the “finned stem” with the “cemented stem” (figure 13). Use a stem of two diameters smaller than the trial one, this will create a cement mantle of 2 mm. Instruments and procedure remain the same.

Fill the canal with cement, then insert the assembled components with the prosthesis introducer using the centimetre gauge to reproduce the same height of the implant that was measured during the trial. Proceed with the surgical technique only when the cement has set.

Pay attention to proximal cleaning of the humeral head and humeral body. The tapers must be free from cement.

SMR PRIMARY SURGICAL TECHNIQUE

SMR Elective Anatomical - Humeral Part

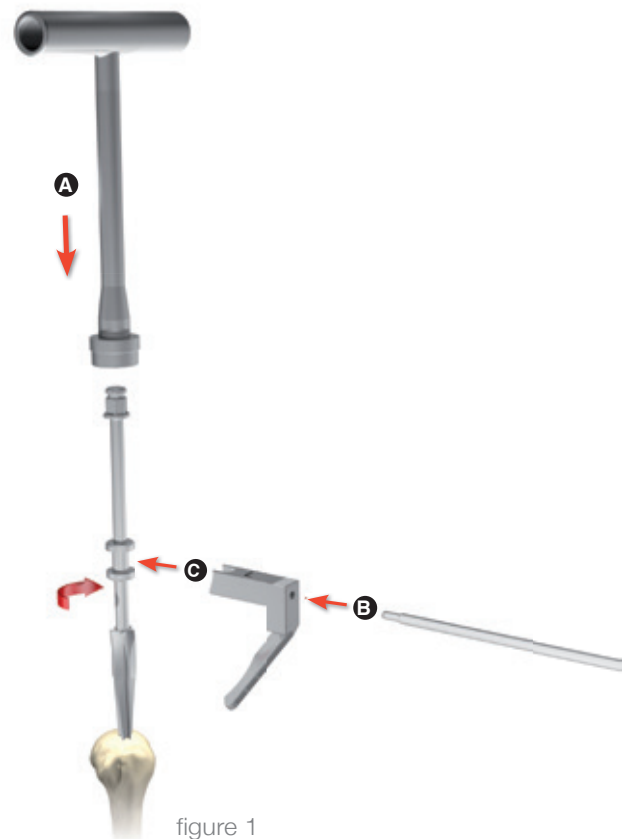
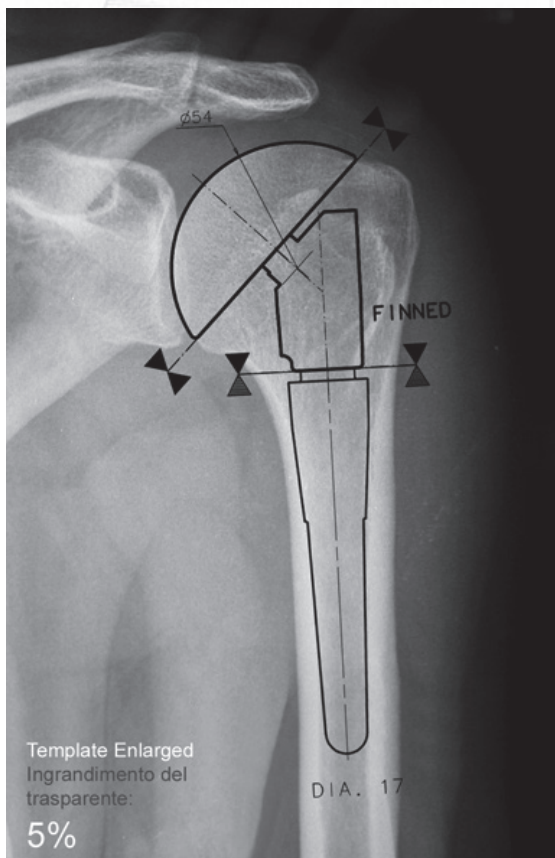

▼ PREOPERATIVE PLANNING

To obtain the best results, pre-operative planning is highly recommended with the use of templates showing a 5% enlarged image of the profiles.

Use good quality frontal view radiographs with adequate contrast that are large enough to contain the entire length of the pre-op template stems.

Select the stem size and resection level of the humeral head, which will serve as a reference for the final implant height.

▼ REAMING OF THE HUMERAL CANAL AND RESECTION OF THE HEAD

REAMING

Open the proximal end of the humerus with a pointed instrument or an osteotome. Insert the *reamer (A1)* with *manual snap wrench (D1)* (figure 1). Insert the reamer by rotating in the canal until the flutes are fully inserted into the canal.

Insert the left or right *resection mask (N2)* on the reamer with the *alignment rod (O2)* to obtain the retroversion angle (figure 1B–C).

Note. When there is a large humeral canal the reamer, which has a proximal diameter of 16 mm, may enter the canal at an incorrect angle with consequent surgical error in the

SMR PRIMARY SURGICAL TECHNIQUE

SMR Elective Anatomical - Humeral Part

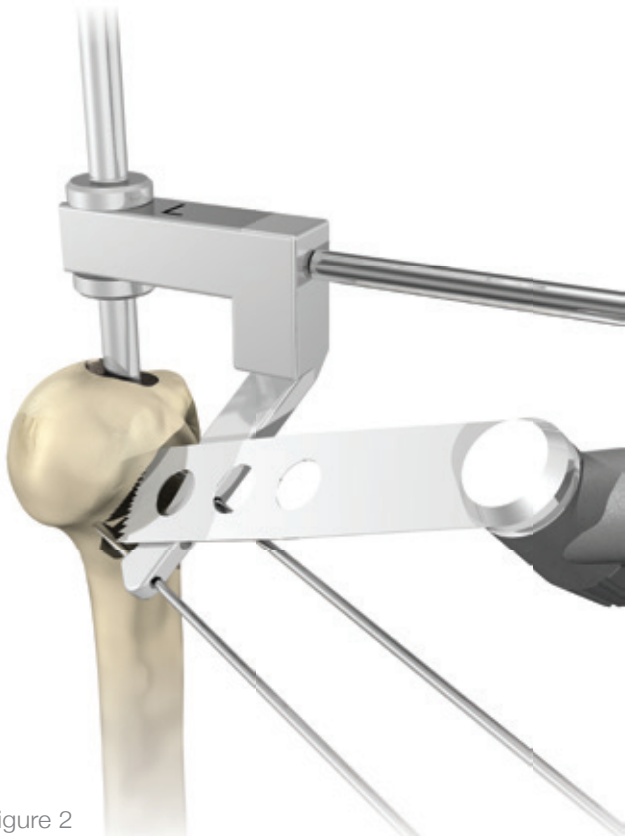

figure 2

resection of the humeral epiphysis. To avoid this problem, apply a trial stem with a larger diameter than the reamer to the *stem impactor (C1)* and tap it into the canal. Position the *resection mask (N2)* on the stem impactor.

If, on the other hand, the humeral canal is small, the reamer will not be able to go in all the way. Therefore apply a trial stem with a smaller diameter to the *stem impactor (C1)* and tap it into the canal.

RETROVERSION

Keeping the forearm flexed at 90°, rotate the resection guide until the *alignment rod (O2)* and the forearm are parallel. A resection with a 30° retroversion will be performed in this position. If less retroversion is required, the rod should be externally rotated.

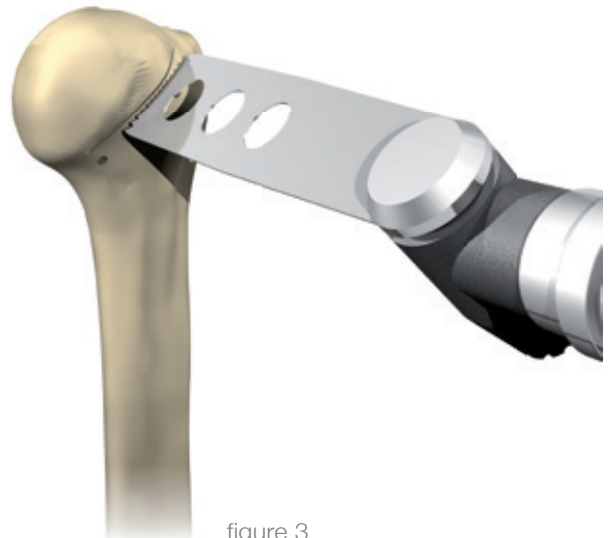

figure 3

HEAD RESECTION

Insert the device used (i.e. reamer or trial stem) in the canal so that the top surface of the guide is level with the anatomic neck. Secure the guide with 2.0 mm Kirschner wires (figure 2). Resect the humeral head with a fine blade resting on the top of the guide surface; perform a partial osteotomy (figure 2). Remove the Kirschner wires, the guide and intramedullary device; then complete the head resection (figure 3). During each of these steps, always take care to remain parallel to the resection planes indicated by the guide to avoid different blade angles of the guide itself. If a glenoid replacement is required please refer to “SMR Glenoid” on page 27.

If needed, the SMR instrument set includes a *humeral cover (B3)* to be applied to the humeral resection plane to protect the resected part.

SMR PRIMARY SURGICAL TECHNIQUE

SMR Elective Anatomical - Humeral Part

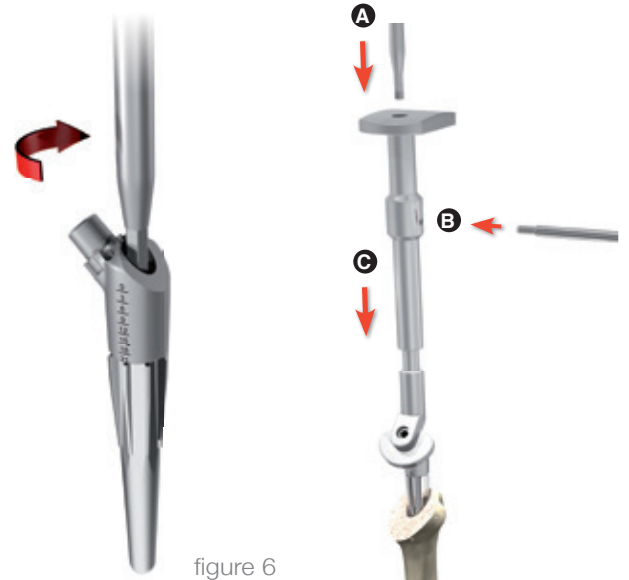

▼ PREPARATION OF THE HUMERUS

CHOICE OF STEM SIZE

Once the glenoid component has been implanted, expose the humerus. Remove the protection cover and prepare the humerus.

Apply the *stem impactor (C1)* to the *trial stem (B1)* (figure 4), tap into the canal (figure 5A) and make sure that the *45° stop guide (M2)* (figure 5B) located in the seat on the impactor rod comes into contact with the resected humeral surface.

Remove the stop and tap the stem in further. If it sinks in, use a stem of the next size up until getting the right one that does not go beyond the resected level. Remove the device and assemble a trial implant of the correct diameter.

Apply the Medium *trial humeral body (G2)* to the stem and tighten the locking screw using the *allen wrench (L2)* (figure 6). Insert the trial implant on the *prosthesis introducer (A2)* and secure it by tightening the proximal screw (figure 7A).

Before inserting into the canal, screw the *alignment rod (O2)* into the prosthesis introducer (figure 7B) and with the arm at 90°, bring the rod parallel to the forearm. In this position, the implant will have a retroversion of 30°.

If a smaller retroversion angle is required, the rod is externally rotated again by an angle at choice. Tap the trial into the canal (figure 7C) until the distal plate of the impactor comes into contact with the resected surface.

SMR PRIMARY SURGICAL TECHNIQUE

SMR Elective Anatomical - Humeral Part

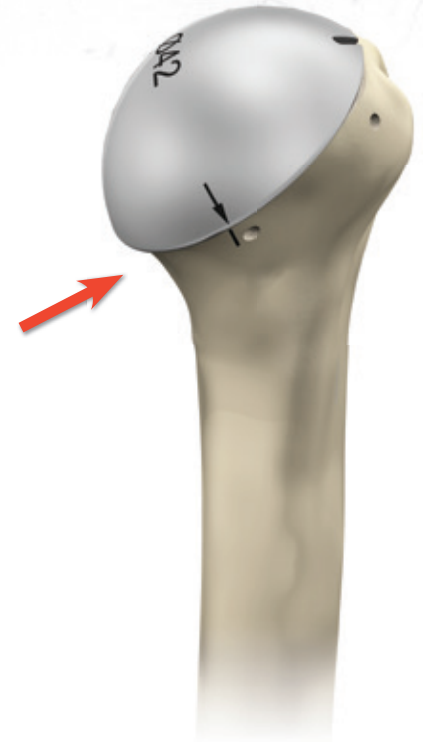

▼ TRIAL ADAPTORS AND HUMERAL HEADS

The head diameter is obtained using the *head gauge (D2)* (figure 8). Insert the *STD neutral trial adaptor (E2)* to the *trial humeral head (C2)* by hand and fit the head to the cephalic taper of the trial humeral body.

If the head rim does not cover the osteotomy surface, substitute the neutral adaptor with an eccentric one, until the prosthetic head covers the entire resected surface.

To remove the trial adaptors, use the *pliers for trial adaptor (F2)* (figure 9). Reduce the shoulder and check the alignment of the head with the glenoid. Resolve any ligamentous laxity using a Long adaptor.

If an eccentric adaptor is used, mark the position of the head with diathermy, using the arrow as a reference. This procedure helps to place the final head in the correct position (figure 10).

Caution! During this step, the head is not press fitted to the neck of the humeral body, therefore when performing a trial reduction, make sure that the head does not uncouple.

SMR PRIMARY SURGICAL TECHNIQUE

SMR Elective Anatomical - Humeral Part



▼ INSERTION OF THE FINNED STEM

Remove the appropriate final finned stem and humeral body from the sterile packaging.

ASSEMBLY OF FINAL COMPONENTS

Connect the implant humeral body and finned stem. The stem and humeral body are assembled together by screwing in the *stem impactor (C1)* with force (figure 11). Remove the impactor and secure the safety screw using the screwdriver (figure 12).

Apply the *prosthesis introducer (A2)* to the prosthesis securing the internal proximal screw.

Tap the implant into the humeral canal. Check the retroversion by inserting the alignment rod into the introducer handle bringing it parallel with the forearm (figure 13). If a smaller retroversion is chosen, the alignment rod must be externally rotated.

Stop the insertion of the implant as soon as the prosthesis introducer plate touches the resected humeral surface.

SMR PRIMARY SURGICAL TECHNIQUE

SMR Elective Anatomical - Humeral Part

figure 15

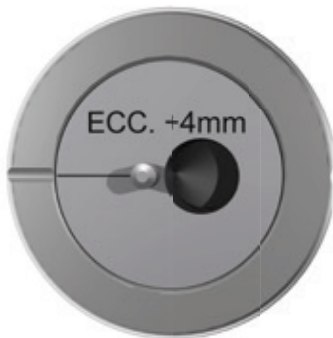
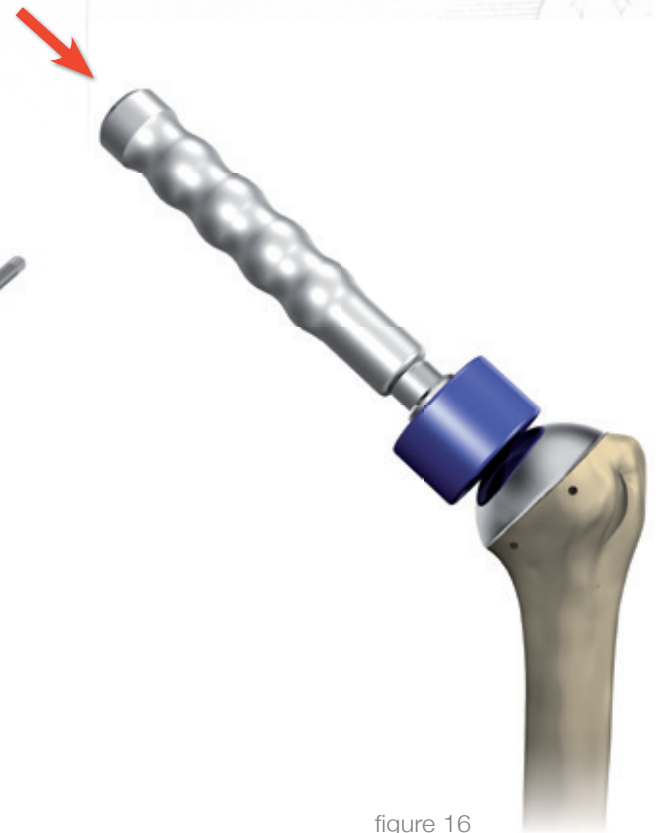

figure 14

figure 16



▼ APPLICATION OF THE ADAPTOR TAPER TO THE HUMERAL HEAD

Remove the appropriate adaptor taper and final head from the sterile packaging. Apply the adaptor taper to the head.

If an eccentric adaptor taper is used, insert it by aligning the marking with that of the humeral head (Figure 14).

The concentric adaptor taper has no such markings.

Position the system in the *humeral head press (R2)* (Figure 15) and turn the handle to tighten. In this way the head-adaptor taper will be connected. Also apply an opposite force with the *alignment rod (O2)*.

▼ INSERTION OF THE HUMERAL HEAD

Apply the chosen humeral head to the cephalic taper. If an eccentric taper is being used, place the head so that the lowered part of the final prosthetic humeral head is in line with the previously marked reference.

Make sure that the contact surfaces are perfectly clean and that the head or adaptor does not interfere with the bone, as this could compromise the stability of the Morse coupling.

Lastly, secure the taper coupling by tapping lightly with the *humeral head impactor (Q2)* in line with the head axis (figure 16); then tap in the diaphyseal axis direction to eliminate the small gap between the head and humeral osteotomy.

SMR PRIMARY SURGICAL TECHNIQUE

SMR Elective Anatomical - Humeral Part



figure 17



figure 18

▼ REDUCTION AND SUTURE

The humeral component is reduced by means of gentle pulling and internal rotation. Reconstruction of the planes.

The capsule is not sutured to prevent rigidity and restriction of the external rotation. Accurate reinsertion of the subscapular muscle is required and fixation by non resorbing trans-bone stitches to the humeral metaphysis.

The use of suction drainage is recommended.

▼ CEMENTED STEM

If cemented stems are used (figure 18), the operating technique is more or less the same. Proceed as described previously. In paragraph "Insertion of the finned stem", replace the "finned stem" with the "cemented stem". Use a stem of a diameter smaller than the trial one. Instruments and procedure remain the same.

Fill the canal with cement, then insert the assembled components with the prosthesis inserter. Proceed with the surgical technique only when the cement has set.

Pay attention to proximal cleaning of the humeral head. The seat of the adaptor taper must be free from cement.

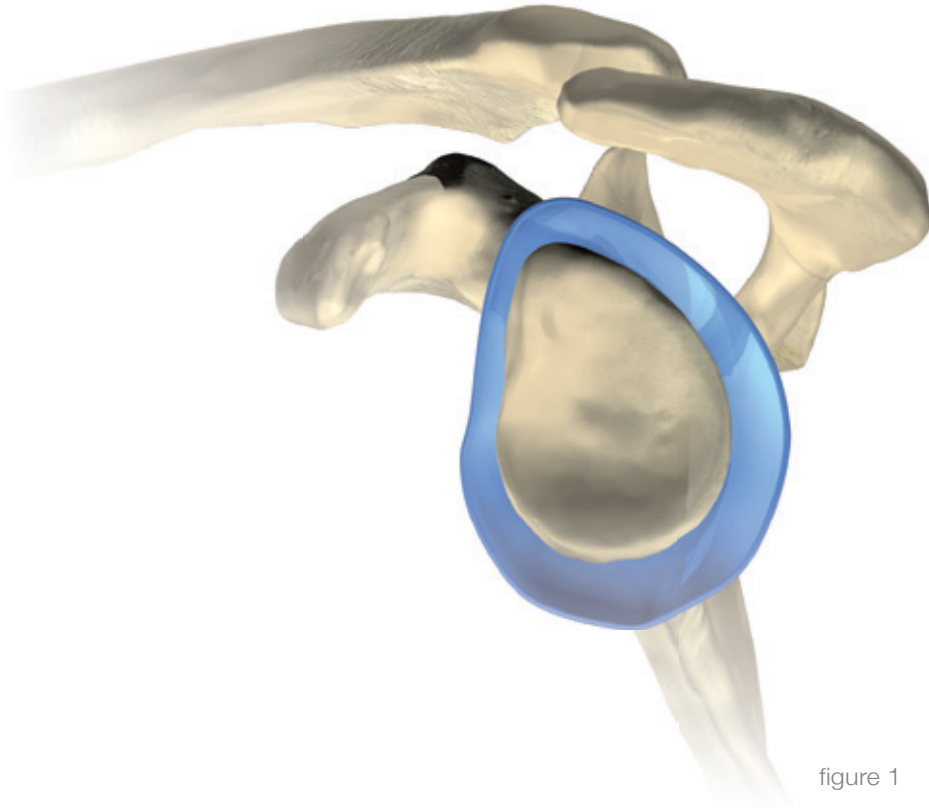

figure 1

Glenoid preparation of a total anatomic or reverse shoulder replacement is carried out after the humeral head has been resected and before insertion of the final humeral prosthesis. With regards to the access and preparatory steps, please refer to the section “Introduction”.

EXPOSURE

Glenoid preparation: a retractor (Hohmann, Fukuda) is placed anteriorly and posteriorly of the glenoid rim. It is important to understand in each case the bony geometry of the glenoid, measured and planned by the preoperative X-ray evaluation.

The *Fukuda retractor (F3)* helps to displace the proximal humerus out of the joint area thereby providing good exposure of the glenoid surface. The retractor is usually

anchored to the posterior rim of the glenoid neck in deltopectoral approach, inferiorly in lateral approach. Removal of the glenoid labrum is recommended so as to highlight the articular surface.

▼ CEMENTLESS GLENOID IMPLANT

The cementless SMR implant is recommended where there is good bone quality which is sufficient to achieve fixation of the peg and the two additional screws.

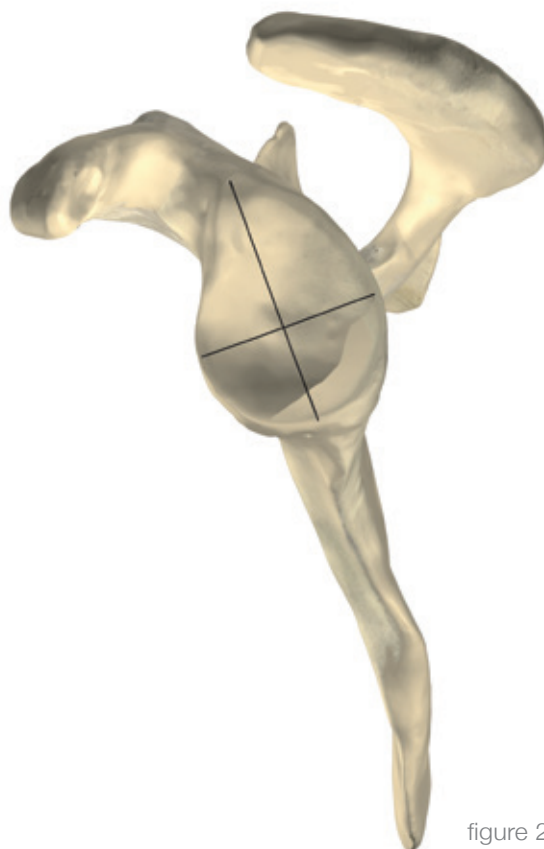

figure 2

DETERMINATION OF THE GLENOID CENTRE

Having completely exposed the glenoid (after resecting the labrum and/or hypertrophic capsular components), trace two perpendicular lines in a cross shape along the main, longitudinal and transversal axes using a diathermy (figure 2).

This operation does not require any particular measurement as its only purpose is to determine the centre of the glenoid and to avoid errors when positioning the implant.

Note. It is important to completely remove all the osteophytes on the glenoid rim. Be careful since the axillary nerve is very close to the inferior rim of the glenoid.

GUIDEWIRE INSERTION

To prepare the glenoid seat, use a 15 cm long, 2.5 mm diameter guide wire. Direct the wire slightly off-centre antero inferiorly and insert it into the bone up to a depth of about 25 mm in a perpendicular direction to the glenoid neck, compensating for any eroded glenoid surface (as for example posterior glenoid wear).

The direction taken by the guide wire will determine the version of the glenoid component (Metal Back). Therefore, a preoperative CT Scan or an MRI is useful to evaluate any deformities in the articular surface.

Any corrections in the wire direction should be made at this point, correction is more difficult once surface is reamed or/ and the central peg is drilled.

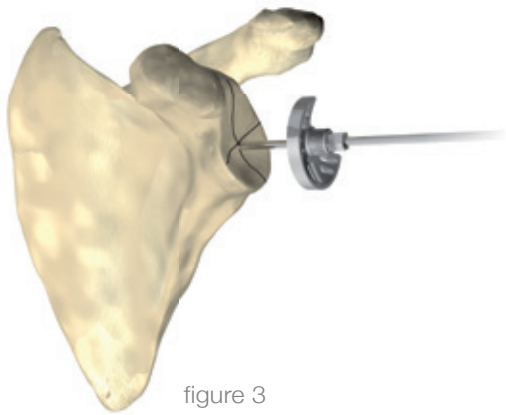

figure 3

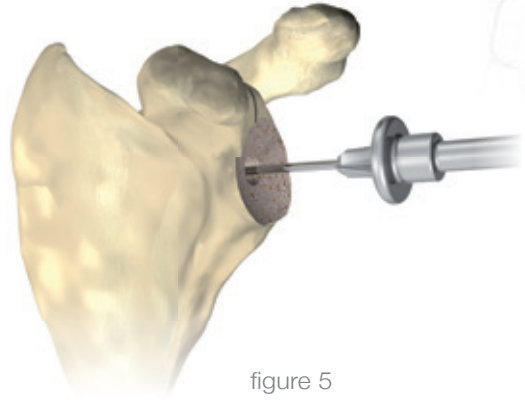

figure 5

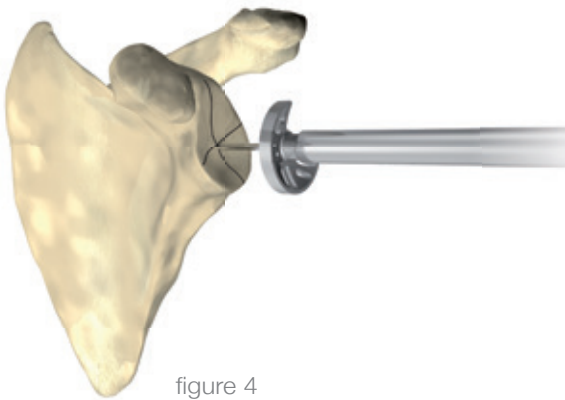

figure 4

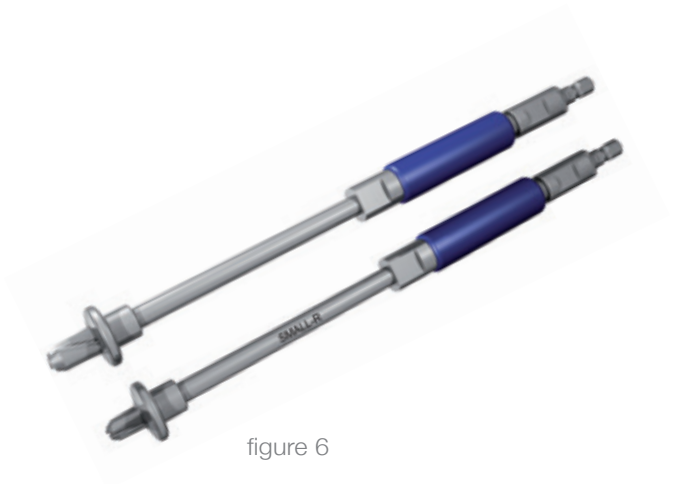

figure 6

PREPARATION OF THE GLENOID SURFACE

Once the Kirschner wire has been inserted, apply first the Small and then, if a larger glenoid metal back is needed, the *STD glenoid reamer (G3)* depending on the glenoid size (figure 3).

Connect the *glenoid reamers shaft (H3)* to power tool and ream the bone surface (figure 4).

Ream carefully to avoid glenoid fractures. The aim of the reaming is to just remove the cartilage and expose the subchondral bone rather than excessive bone removal.

Remove the reamer leaving the K wire in place and follow on with drilling using the *Small-R glenoid drill (D3)*. Insert until it comes to the reamer base plate (figure 5).

If a metal back component with a larger peg is needed, insert the *Small/STD glenoid drill (D3)* (figure 6) over the K wire and widen the hole.

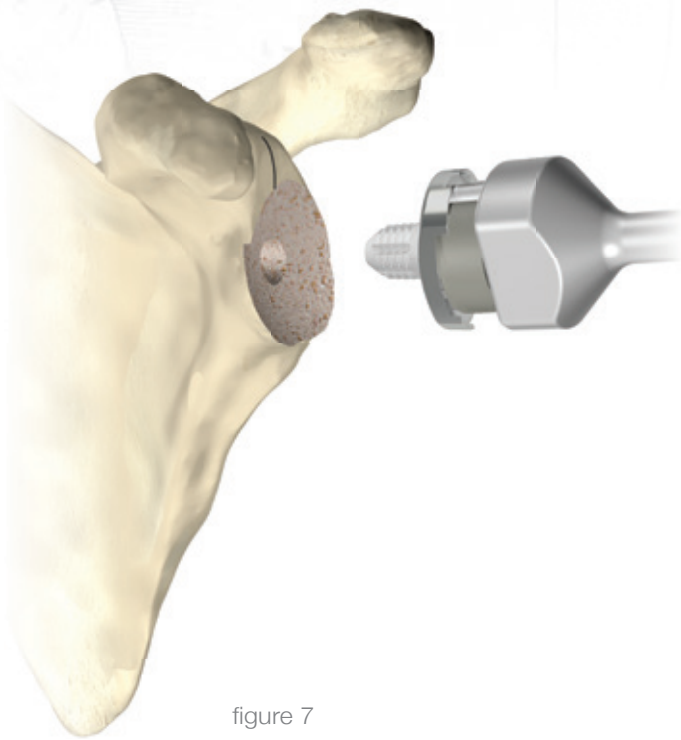

figure 7

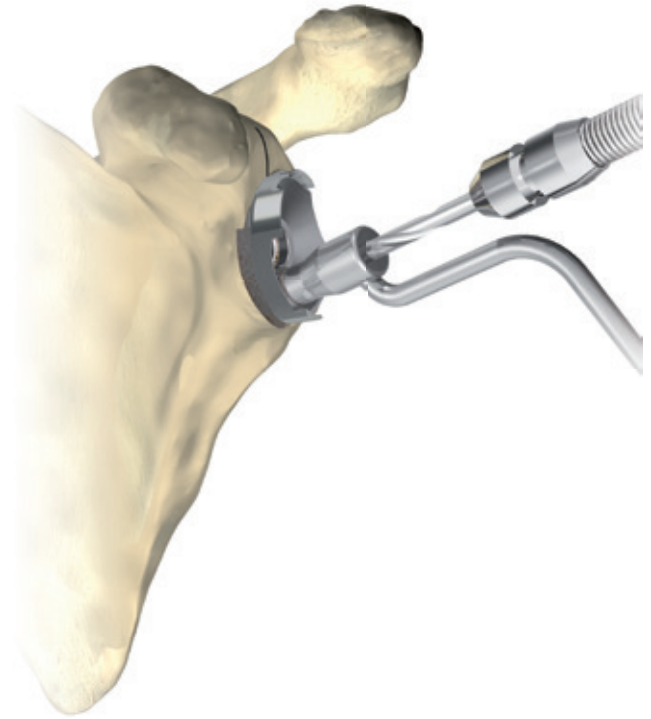

figure 8

INSERTION OF CEMENTLESS GLENOID

Remove the M-B component of the chosen size from the sterile packaging and apply it to the *M-B glenoid impactor (C3)*. Push the prosthesis central peg in the hole made beforehand by tapping it in with the positioner handle (figure 7). The axis of the prosthesis should be perpendicular to the glenoid face.

INSERTION OF BONE SCREWS

Once the cementless glenoid has been positioned, drill for the fixing screws using a *flexible mandrel (K3)* with a *3.5 helix drill (M3)* inserted on the *drill guide (I3)* (figure 8).

The screw head seated on the metal back shell is spherical therefore able to be secure up to 30°.

The superior screw is recommended to be directed to the base of the coracoid, while inferior screw dorsally.

After drilling for the first screw, insert the screw using a plain *screwdriver (L3)* but do not tighten fully until the next hole has been prepared and screw inserted.

The screws must be tightened at the same time to guarantee the best fit of the metal glenoid in the prepared bone.

ANATOMICAL LINER INSERTION

Remove the polyethylene glenoid liner of the same size as the cementless glenoid from the sterile packaging and after having carefully cleaned the inside and edges of the M-B shell from fat and soft tissues, push the liner

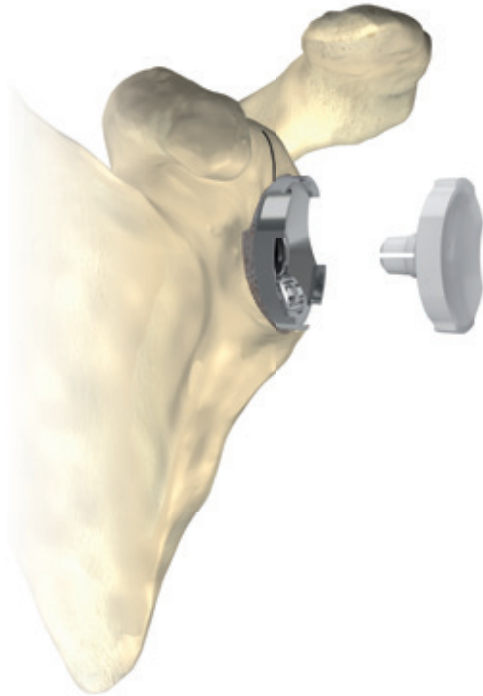

figure 9

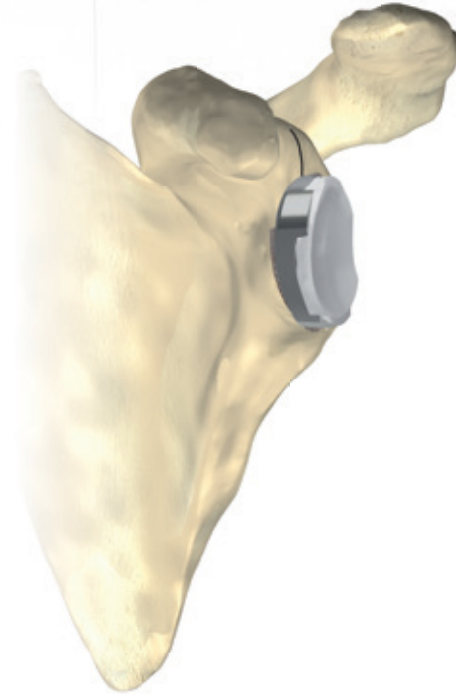

figure 10

until it snaps in (Figure 9).

Note. Insertion is not reversible. If the liner has just been inserted and needs to be removed, open another liner of the same size and reinsert the liner after the removal of the previous liner. During the next steps, be aware not to damage the liner with metal objects. Gently remove humeral retractors, avoiding any impingement with the previously implanted prosthesis.

▼ CEMENTED GLENOID IMPLANT (ONLY FOR ANATOMICAL PROSTHESIS)

The cemented implant is recommended when good bony fixation of the central peg and additional screws of the cementless SMR glenoid cannot be guaranteed. Proceed as described beforehand for preparing the glenoid.

PROSTHESIS SELECTION AND FIXATION

Remove the appropriate polyethylene glenoid from the sterile packaging. Make sure that the prosthesis fits perfectly into the seat that has been prepared beforehand. Place the acrylic cement in the cavity and insert the final glenoid component, pressing it in with the *cemented glenoid impactor (E3)* until the cement has completely set. Make sure that the cement covers all the seat; this ensures the complete cementation of both the glenoid peg and backside.

SMR PRIMARY SURGICAL TECHNIQUE

SMR Reverse

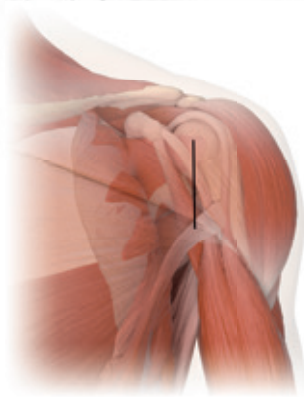

DELTO-PECTORAL

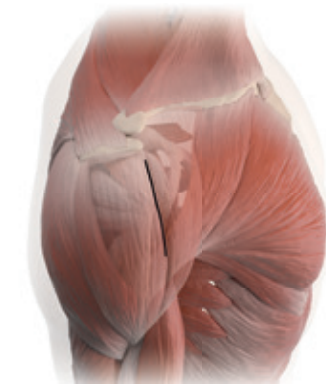

DELTOID SPLIT

▼ ACCESS

The SMR reverse prosthesis can be implanted with one of the usual approaches:

- delto-pectoral
- deltoid split

The operating technique described here below is independent from the chosen approach.

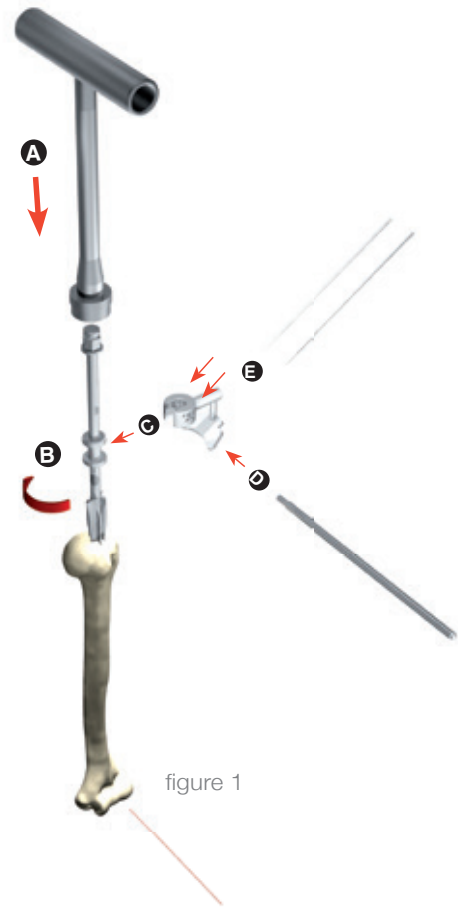

figure 1

▼ REAMING OF THE HUMERAL CANAL AND RESECTION OF THE HEAD

REAMING

Insert the *reamer (A1)* in the canal with the *manual snap wrench (D1)* by rotating until it fits in (the flutes disappear in the canal) (figure 1A-B).

Insert the reverse *resection mask (I4)* on the reamer (figure 1C). Select a retroversion angle for the implant (20° or 0°) depending on the clinical case and screw the corresponding *alignment rod (O2)* into the hole (figure 1D). If there is a large humeral canal, the reamer, which has a proximal diameter of 16 mm may enter the canal at an incorrect angle with consequent surgical error in resection of the humeral epiphysis.

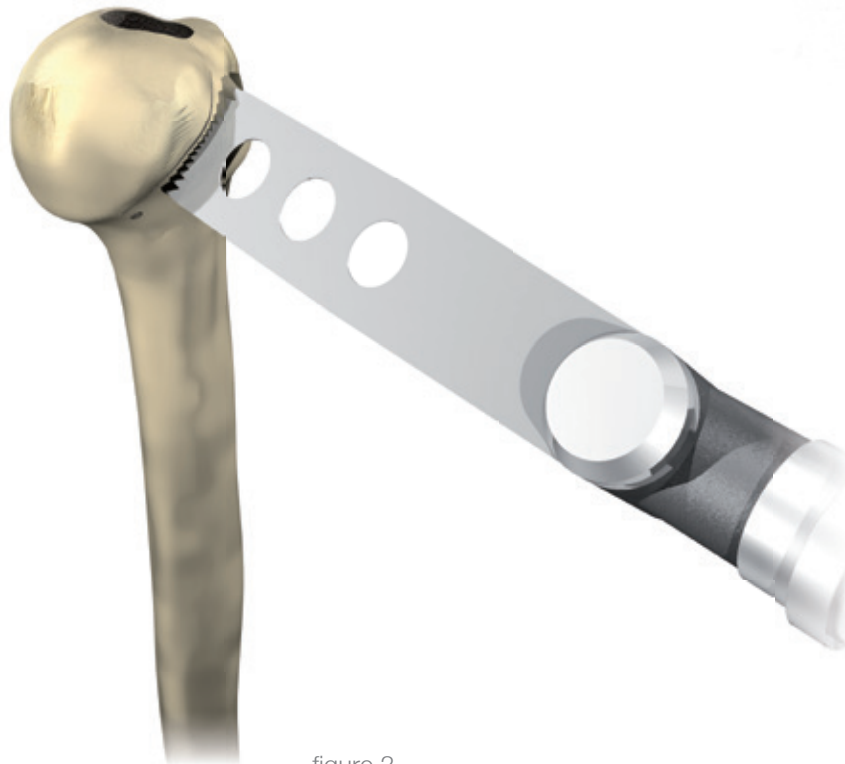

figure 2

To avoid this, apply a *trial stem (B1)* with a larger diameter than the reamer to the *stem impactor (C1)* and tap into the canal, then position the resection guide.

RETROVERSION

Keeping the forearm flexed at 90° rotate the *resection mask (I4)* until the *alignment rod (F4)* and the forearm are parallel to each other.

Note. If a smaller retroversion angle is chosen, externally rotate the alignment rod that is connected to the resection guide; if the retroversion angle is greater, internally rotate the guide.

HEAD RESECTION

Insert the device used (reamer or trial stem) in the canal so that the top surface of the guide is close to the greater tuberosity.

Secure the guide with 2 mm Kirschner wires and resect the humeral head with a fine blade resting on the guide surface; perform a partial osteotomy. Remove the Kirschner wires, the retroversion guide and the reamer; then complete the resection of the head (figure 2) .



figure 3

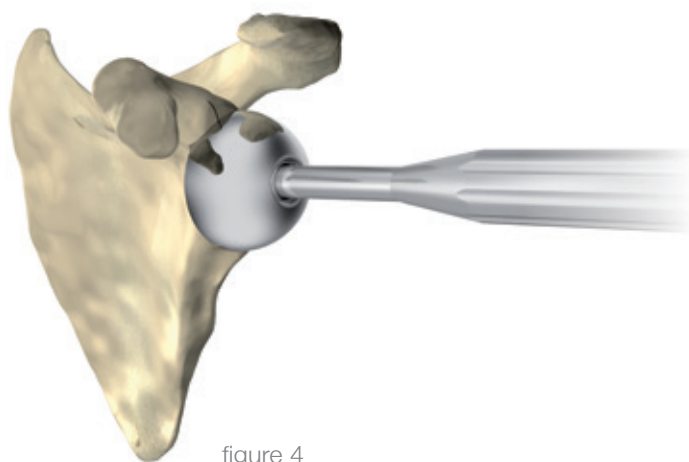

figure 4

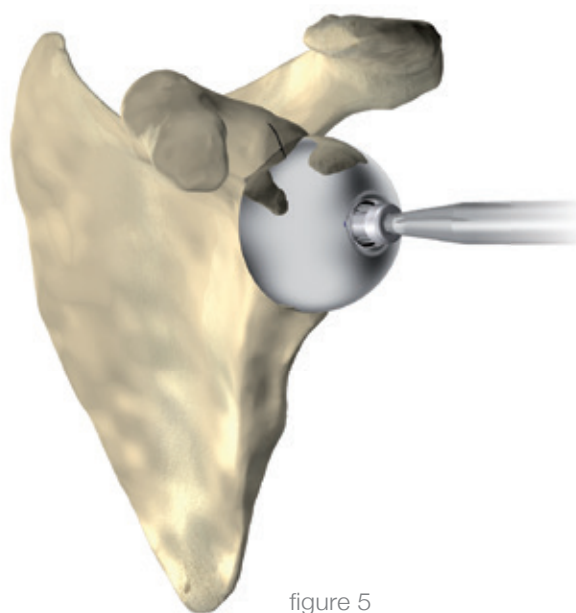

figure 5

▼ GLENOID IMPLANT

CEMENTLESS GLENOID INSERTION

With the reverse prosthesis, the glenoid component is a cementless implant as outlined in “SMR Glenoid”. Follow the procedure of the metal back component described in the section “SMR Glenoid” on page 27.

INSERTION OF THE FINAL 36 MM CONCENTRIC GLENSPHERE

Open the package of the final glenosphere.
Insert the peg in the appropriate taper on the glenosphere and secure the components by tapping in.
Screw the knurled part of the *glenosphere impactor-extractor (T4)* into the glenosphere's apex hole and insert the assembly into the glenoid cavity (figure 4). Using a mallet tap in the morse taper coupling.
Unscrew the impactor and check by hand that the morse taper is stable. Insert a safety screw, which is provided in the package (figure 5), using the *screwdriver (L3)*.

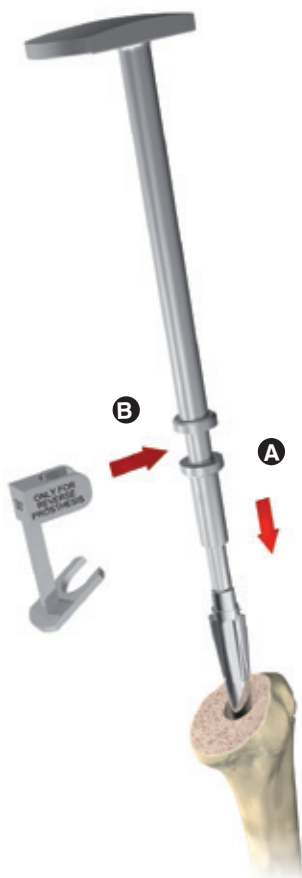

figure 6



figure 7

▼ PREPARATION OF THE HUMERUS

CHOICE OF STEM SIZE

Screw the *stem impactor (C1)* onto the *trial stem (B1)*, tap it into the canal with a mallet and make sure that the *30° stop guide (N4)* positioned in the seat on the impactor comes into contact with the resected surface (figure 6).

Remove the stop and tap the stem in further. If this sinks in, take the next size up until the right one that does not go beyond the level established.

Remove the device once the right stem size has been found.

PREPARATION OF THE HUMERUS FOR REVERSE BODY INSERTION

Take the *guide for conical reamer (J4)* from the instrument set and apply to the correctly sized trial stem (tapered fit) (figure 7A).

Take the plastic base off the *humeral body impactor (L4)* to allow connection to the reamer guide.

Place the impactor-positioner in the groove of the *guide for conical reamer (J4)* and with the thumb press the proximal end until the peg clicks in (figure 7B). Then use the impactor-positioner to tighten the reamer guide peg and the trial stem, screwing it to the end. Slightly loosen the fastening.

This loosening avoids any risky torsion that could damage the humerus when removing the impactor.

SMR PRIMARY SURGICAL TECHNIQUE

SMR Reverse



figure 8



figure 9



figure 10



figure 11



figure 12



figure 13

figure 14

Insert it in the canal with the help of the *alignment rod (F4)* to obtain the angle in the same way as for the resection guide (figure 8).

The *humeral body impactor (L4)* is removed by unscrewing the top part and then flexing the handle sideways a little (this eliminates the reaction due to the spring grub screw) and lifting it (figure 9).

Ream using the *conical reamer (K4)* mounted on the *manual snap wrench T handle (V4)* (figure 10). This step must be carried out carefully.

To make sure that the humeral part has been completely prepared, insert a Kirschner wire (dia. 2.0 mm) in the reamer hole near the cutting teeth (figure 11). If the Kirschner wire passes through, then the humeral reaming has not been completed.

INSERTION OF THE TRIAL REVERSE HUMERAL BODY

Once the humeral metaphysis has been reamed, remove the reamer guide using the *stem impactor (C1)* (figure 12).

Disassemble the reamer guide peg from the trial stem, using the following method: screw the *extractor for the humeral body (C4)* on the reamer guide peg and then the *universal stem extractor (D4)* in it (figure 13); when resistance is felt, hold tightly the knurled part and screw in with force using the *manual snap wrench (V4)*. This splits the trial stem away from the reamer guide (figure 14).



figure 15



figure 16

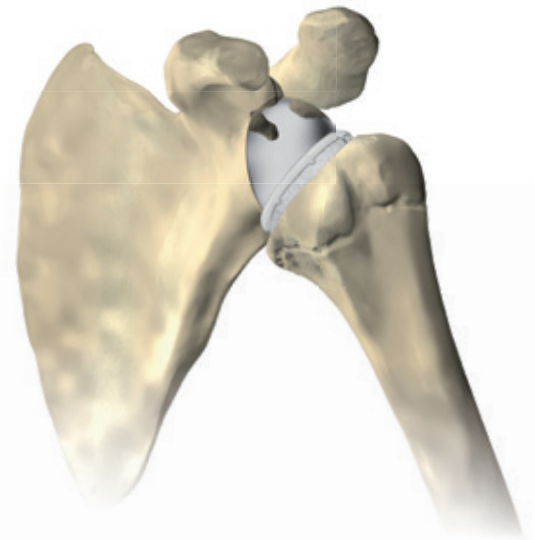

figure 17

Take the *trial reverse humeral body (H4)* from the instrument set and assemble it on the trial stem (tapered fit).

Apply the mobile plastic part to the bottom of the impactor positioner and assemble it in the same way as the reamer guide peg. Using the positioner, gently tap it into the metaphysis with the help of the alignment rod to obtain the version angle (figure 15).

Note. If the trial reverse body has to be removed, use the *extractor for the humeral body (C4)* in the same way as the *guide for conical reamer (J4)*.

REDUCTION AND MODIFICATION OF THE COMPONENTS

Expose the humerus and insert the *STD trial liner (O4)* by hand (figure 16). Reduce the final glenosphere that has

been implanted (figure 17). Assess the joint tension and address any laxity by replacing the STD size with a +3 or +6 liner.

To remove and replace a trial liner, insert a Kocher clamp through one of the holes or use a pointed chisel on the side edge as a lever. If necessary, make up for any laxity by placing a +9 mm humeral extension in between.

If necessary, rotate the liner until the chamfer comes up to the contact point with the bone, thereby increasing the range of motion of the new joint.

Then assess the articular congruence and if necessary turn the insert by positioning the chamfer near the greater tuberosity. Note the last liner position used.

SMR PRIMARY SURGICAL TECHNIQUE

SMR Reverse



figure 18



figure 19

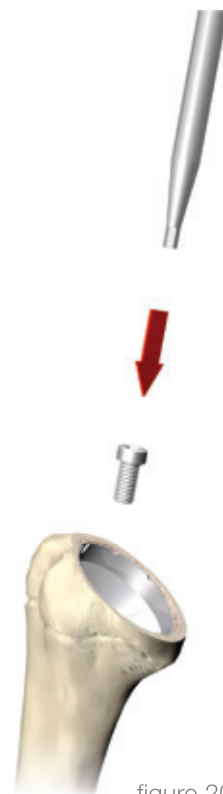

figure 20

▼ INSERTION OF THE FINAL IMPLANT

ASSEMBLY OF THE FINAL STEM AND REVERSE HUMERAL BODY

Remove the trial implant using the stem impactor (figure 18).

Assemble the final humeral body and finned stem on the back table with the use of the *humeral body impactor (L4)*. Screw the impactor-positioner tightly to join the stem and humeral body.

The hole passing through the impactor can be used to insert the *alignment rod (O2)*, which is used here as a counter-torque. Slightly loosen the fastening to avoid risky torsion that may damage the humerus when removing the impactor (figure 19).

INSERTION OF THE FINAL HUMERAL COMPONENTS

Tap the implant into the canal. Correct version is obtained by using the *alignment rod (O2)* again. Once the reverse body has been inserted fully on the resection level, unscrew the impactor handle, insert the safety screw of the reverse body (figure 20) and tighten with the dedicated *allen wrench (E4)*.

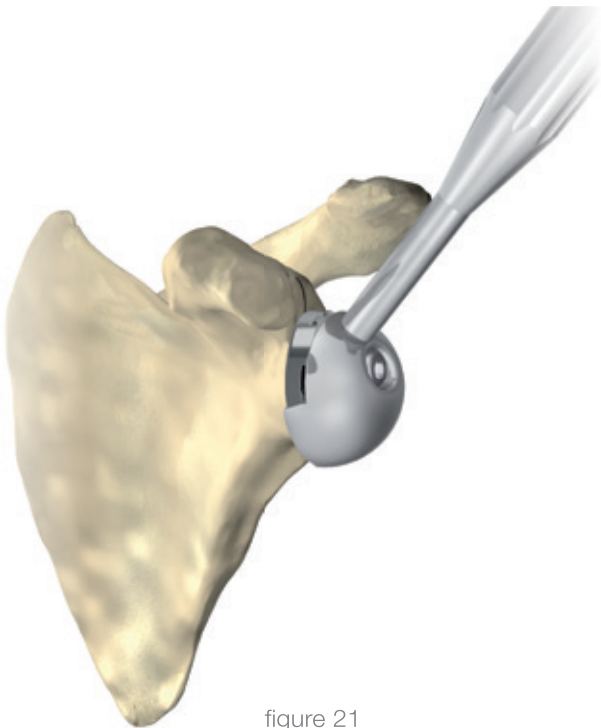

figure 21

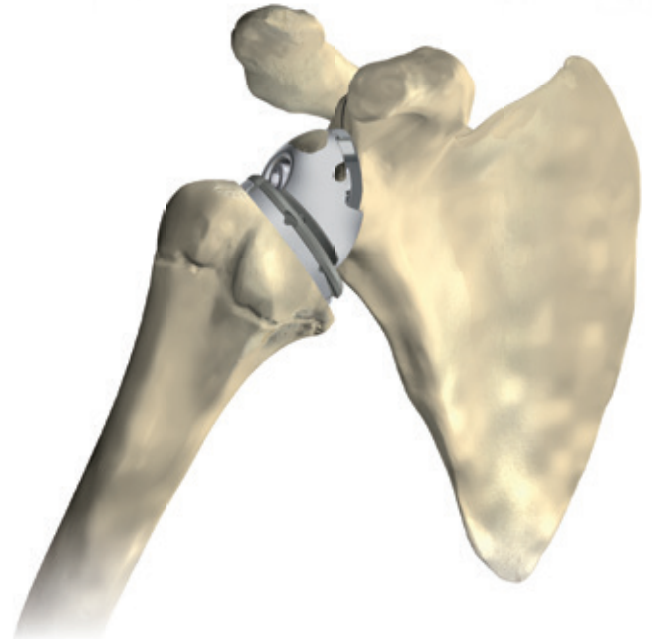

figure 22

USE OF THE 36 MM ECCENTRIC TRIAL GLENOSPHERE

Screw the eccentric trial glenosphere to the *glenosphere impactor-extractor (T4)* in the hole at the top edge and position it near the glenoid metal back (figure 21).

Slide the *trial glenosphere screw (P4 or R4)* through the central hole and using a simple screwdriver, tighten until reaching the end stop, keeping the eccentricity of the component in one of the bottom quadrants of the glenoid.

TRIAL SURGICAL REDUCTION AND MODIFICATION OF THE COMPONENTS

Expose the humerus and insert the *STD trial liner (O4)* by hand.

Reduce the trial glenosphere that has been implanted (Figure 22).

Assess the joint tension and address any laxity by replacing the STD size with a +3 or +6 liner.

To remove and replace a trial liner, insert a Kocher clamp through one of the holes or use a pointed chisel on the side edge as a lever.

Assess stability with dynamic rotational movements with the arm abducted and adducted and, if necessary, rotate the glenosphere on the metal back until the most stable position for the new joint has been obtained.

At the same time find the best position for the liner to give stability without restricting the range of motion. Note the last position used for the liner and trace a reference point in relation to one of the two surrounding steps of the glenosphere.

SMR PRIMARY SURGICAL TECHNIQUE

SMR Reverse

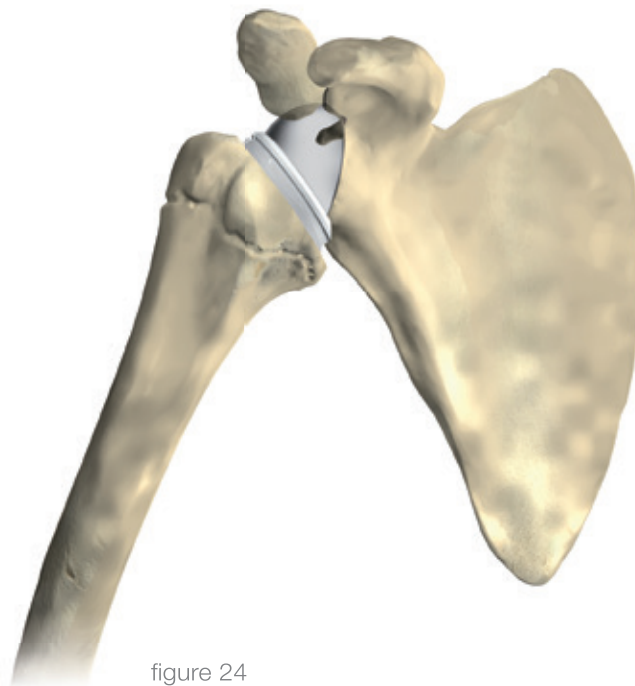
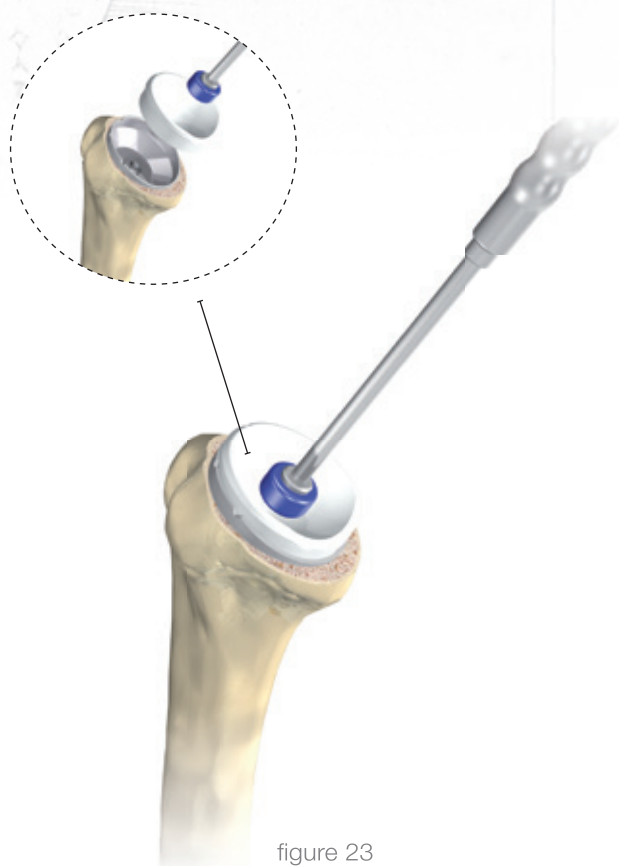

INSERTION OF THE FINAL REVERSE LINER

Open the packaging of the liner that was selected during the trial reduction. With the 36 mm glenosphere, pay attention as the associated polyethylene liner has a 25° chamfer along the external profile and is positioned to reproduce the range of motion and stability achieved with the trial reductions.

Clean inside the reverse humeral body, press gently with the fingers and push the liner in with the *cemented glenoid impactor (E3)* (figure 23).

If using an humeral extension +9 mm, screw the *extractor for humeral body (C4)* and impact it.

REDUCTION

Perform the usual articular movements (figure 24). Check that any humeral and glenoid osteophytes are carefully removed.

To get the appropriate joint tension, perform after reduction all shoulder movements. With slight longitudinal traction there should be no disassembling of humeral body to glenosphere. Palpating the axillary nerve should find a normal structure tension as before surgery.

This test also avoid postoperative axillary neuropathic lesions.

The definitive eccentric implant will be implanted in the same way of the concentric one as described on page 34. A safety screw will also be added.

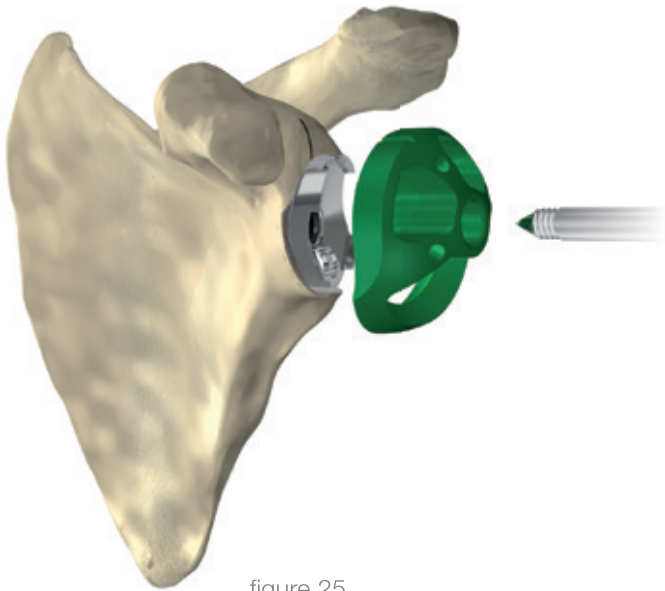

figure 25

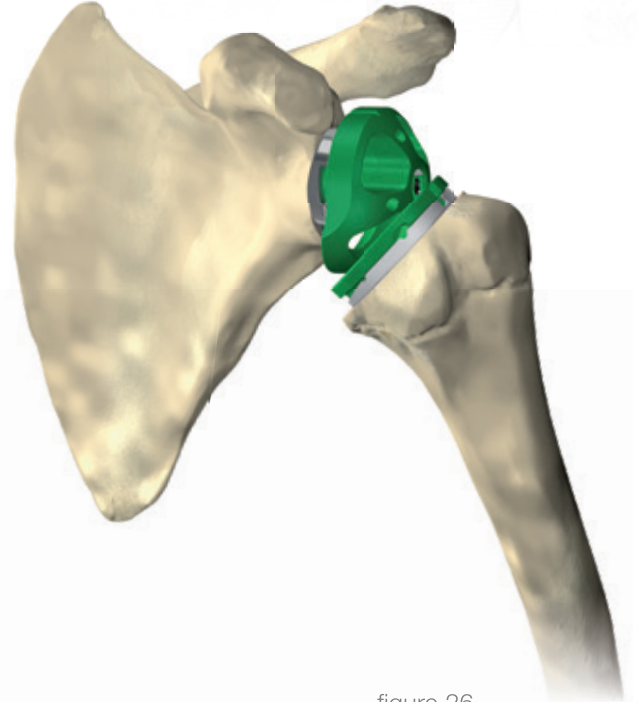

figure 26

▼ USE OF 40 OR 44 MM GLENOSPHERE

INSERTION OF THE TRIAL 44 OR 40 MM GLENOSPHERE

Apply the *trial glenosphere* (E42 or F42) and position it near the glenoid Metal Back (figure 25).

Slide the trial glenosphere screw through the central hole and tighten until reaching the end stop.

If a correction is required due to anatomic variation or to surgical malpositioning of the metal back, the system allows a corrective version of the 44 mm diameter size with a *4 mm eccentric glenosphere* (F42). Maintain the eccentricity of the component in one of the bottom quadrants of the glenoid and tighten the module in the same way as for the concentric 44 mm glenosphere.

TRIAL SURGICAL REDUCTION AND MODIFICATION OF THE COMPONENT

Expose the humerus, insert the *SHORT trial liner* (A42 or B42) in the proper position by hand and reduce the implanted glenosphere.

Assess the joint tension and avoid any laxity by replacing the SHORT size with a MEDIUM or LONG one. To remove and replace a trial liner insert a sharp object through one of the two holes or use a pointed chisel on the side edge as a lever. If necessary, make up any deficit by replacing a *+9 humeral extension* (G4) in between. Reverse liner of 44 or 40 mm Glenosphere do not have the classical chamfer along the outer profile. Therefore, the position of the liner on the reverse body does not influence joint stability. Perform the usual articular movements, check that any humeral and glenoid osteophytes are carefully removed (figure 26).

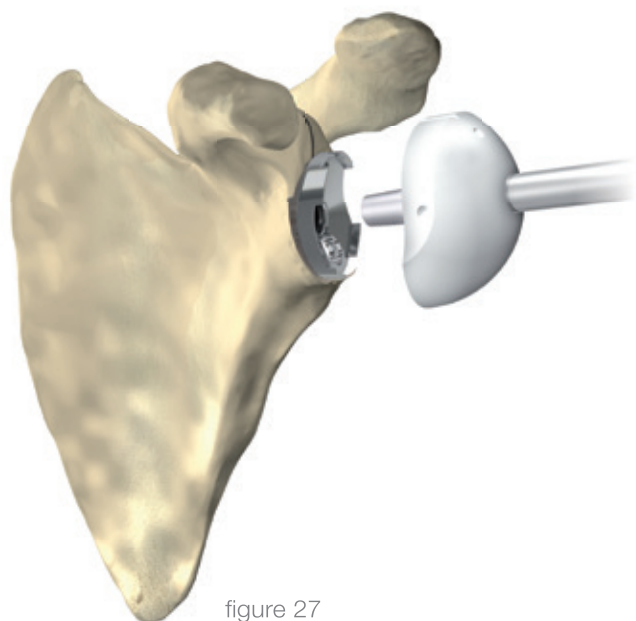

figure 27

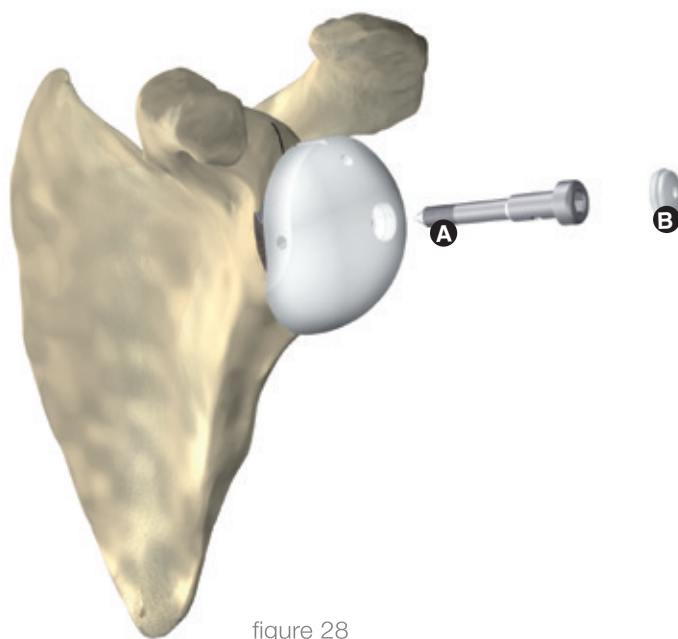

figure 28

INSERTION OF THE FINAL 44 OR 40 MM GLENSPHERE

The polyethylene 44 and 40 mm glenosphere do not come in a package with peg Small-R / Small-STD and safety screw.

Open the package containing the peg and screw relating to the size of the implanted metal back, then the selected glenosphere package (standard or corrective).

Assemble the peg on the sphere by tapping. Screw the *glenosphere impactor-extractor (T4)* in the central hole on the top edge of the glenosphere and insert the system in the metal back (figure 27). Couple the Morse taper. Unscrew the handle and fasten by tightening the safety screw (figure 28A). Press-fit the central cap in the central hole of the implanted component (figure 28B) using the *positioner for glenosphere plug (G42)*.



figure 29



figure 30



figure 31

INSERTION OF THE FINAL 40 OR 44 MM REVERSE LINER

The final liner in CoCrMo will be positioned on the top of the reverse humeral body in the same way as for the 36 mm liner (figure 29).

INSERTION OF THE FINAL 44 MM REVERSE CERAMIC LINER

The final ceramic liner (Medium or Long) will be positioned on the top of the reverse Humeral body. Clean inside the reverse humeral body, press gently with the fingers and push the liner with the specific ceramic liner impactor (figure 30).

ATTENTION! This product is intended to be used with 44 mm glenosphere only. Do not re-connect the removed

ceramic liner, nor insert a new one into a humeral body lodged a ceramic or metal liner before.

REDUCTION

Perform the usual articular movements (Figure 31). Check that any humeral and glenoid osteophytes are carefully removed. To get the appropriate joint tension, perform after reduction all shoulder movements. With slight longitudinal traction there should be no disassembling of humeral body to glenosphere.

Palpating the axillary nerve should find a normal structure tension as before surgery. This test also avoid postoperative axillary neuropathic lesions.

SMR PRIMARY SURGICAL TECHNIQUE

SMR CTA Head

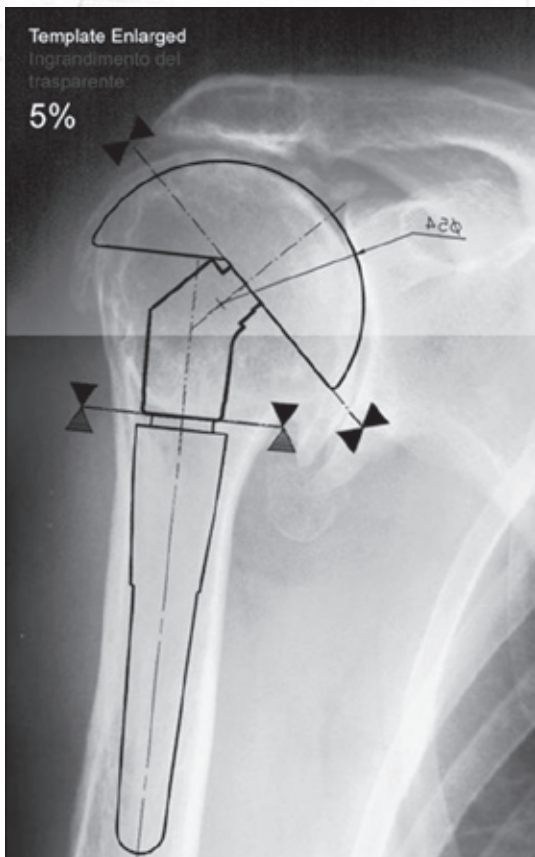

▼ FOREWORD

The clinical indication for prosthetic treatment with CTA heads is secondary osteoarthritis by cuff tear arthropathy with or without humeral head fracture sequelae.

▼ PREOPERATIVE PLANNING

To obtain the best results, preoperative planning is highly recommended with the use of templates showing a 5% magnified image of the profiles. Use good quality frontal view radiographs with adequate contrast that are large enough to contain the entire length of the pre-op template stems. Select the stem size and resection level of the humeral head, which will serve as a reference for the final implant height.

▼ REAMING OF THE CANAL AND DEFINITION OF THE OSTEOTOMY PLANE

Enter the proximal end of the humerus using the *reamer (A1)* near the head-greater tuberosity interline and with the help of a *resection mask (N2)* assess the depth reached.

Insert the reamer so that the resection guide plate is near the anatomic neck. Secure the guide and start bone resection as outlined in chapter "SMR Elective Anatomical-Humeral Part" (figure 1) on page 20.

Proceed with the head resection as outlined in the same section.



figure 2



figure 3

▼ HUMERUS PREPARATION

INSERTION OF THE TRIAL IMPLANT AND REDUCTION

Once the osteotomy has been completed, find the stem size as outlined in “SMR Elective Anatomical – Choice of stem size”, apply a Medium sized *pliers for trial adaptor (F2)* to the trial stem and tap into the canal (figures 2-3) using the *prosthesis introducer (A2)*.

Using the *head gauge (D2)* measure the head component size and with the *pliers for trial adaptor (F2)* apply a *STD neutral adaptor (E2)* to the corresponding *trial humeral head (C2)*. Assemble the components and perform a trial reduction. Assess the motion of the new joint during traction and relaxation of the limb, correct for articular laxity using a LONG adaptor.

If this is not sufficient the use of an *STD neutral adaptor (E2)* should be used to raise or lower the centre of rotation of the head along the cranial-caudal axis.

Lastly, check the head measurement by internal and external rotating movements in relation to the overall space filled by the component and to the tension in the residual tendons.

SMR PRIMARY SURGICAL TECHNIQUE

SMR CTA Head

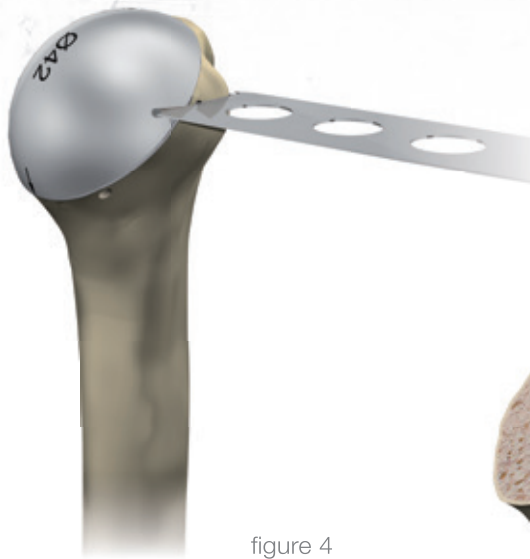

figure 4



figure 5



figure 6

DEFINITION OF THE OSTEOTOMY SIDE PLANE

Once the head and adaptor taper sizes match the required anatomy keep the components in the selected position and with an oscillating blade cut the greater tuberosity through the slot in the trial head (figure 4). Remove the head and complete the bone resection (figure 5).

Assemble the adaptor and CTA trial head and proceed with reduction.

Note. The slot in the trial head provides an indication of the osteotomy level only for neutral positioning or with cranial/caudal eccentricity of the head component.

▼ INSERTION OF THE FINAL IMPLANT

ASSEMBLY AND INSERTION OF THE STEM AND HUMERAL HEAD

Remove the stem and the TRAUMA humeral body of the size required from the sterile package. Assemble the pieces as described in the section “SMR TRAUMA-Insertion of the stem and final body” on page 17 and insert it in the canal following the standard procedure (figure 6).

Insert the component up to the level of the anatomic osteotomy plane performed.

SMR PRIMARY SURGICAL TECHNIQUE

SMR CTA Head



figure 7



figure 8

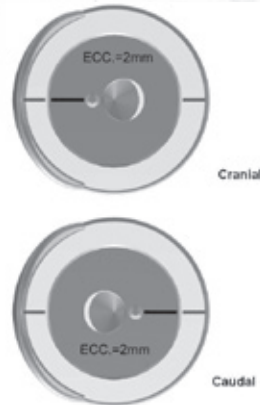

figure 9

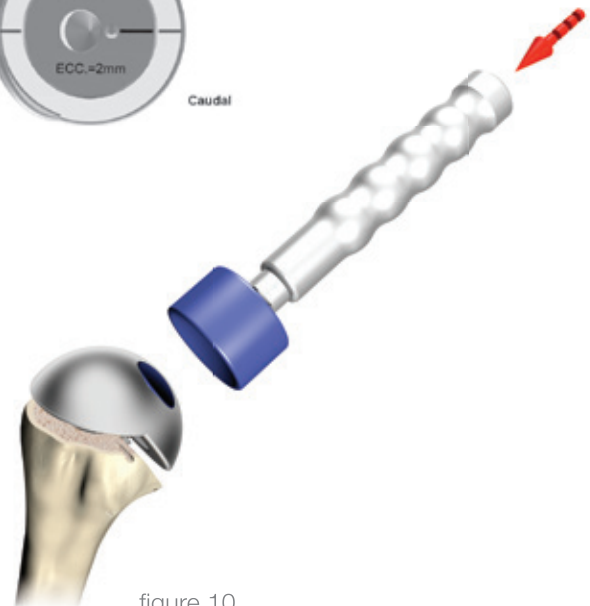

figure 10

ASSEMBLY OF THE ADAPTOR TAPER AND HEAD

Take the adaptor taper and head of the required size from the package (figure 7) and fit the components together using the *humeral head press (R2)* (figure 8).

If an eccentric adaptor taper is used, make sure that the marking is aligned with the lateral interline for cranial positioning of the head, or medial interline for caudal positioning (figure 9).

Use an intermediate position to increase or reduce the posterior offset of the head.

HUMERAL HEAD INSERTION

Apply the selected humeral head on the cephalic taper. If an eccentric adaptor is used, apply the head making sure that the selected offset is observed.

Make sure that the coupling surfaces are properly cleaned and that the head or adaptor do not impinge with the bone, which could compromise the stability of the Morse coupling. Make the coupling sturdy by gently tapping with the *humeral head impactor (Q2)* (figure 10).

If there is any gap, tap in further towards the diaphyseal axis.

SMR PRIMARY SURGICAL TECHNIQUE

Instrument set

- ▼ 9013.10.000 'Common' Instrument Set for SMR Shoulder Prosthesis

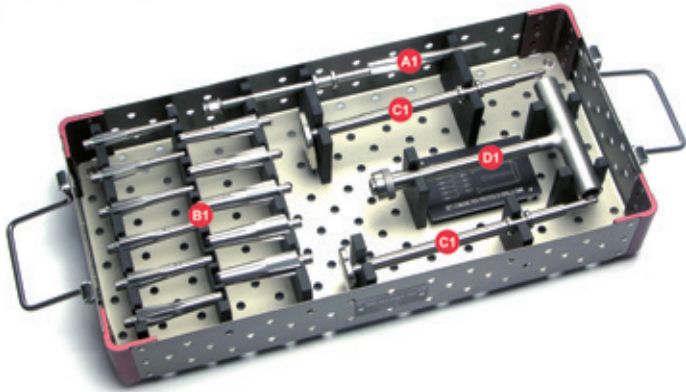

Ref.	CODE	DESCRIPTION	Qt.
A1	9013.02.014	Reamer	1
B1	9013.02.140	Conical Trial Stem Dia. 14	1
B1	9013.02.150	Conical Trial Stem Dia. 15	1
B1	9013.02.160	Conical Trial Stem Dia. 16	1
B1	9013.02.170	Conical Trial Stem Dia. 17	1
B1	9013.02.180	Conical Trial Stem Dia. 18	1
B1	9013.02.190	Conical Trial Stem Dia. 19	1
B1	9013.02.200	Conical Trial Stem Dia. 20	1
B1	9013.02.210	Conical Trial Stem Dia. 21	1
B1	9013.02.220	Conical Trial Stem Dia. 22	1
B1	9013.02.230	Conical Trial Stem Dia. 23	1
B1	9013.02.240	Conical Trial Stem Dia. 24	1
C1	9013.02.300	Stem Impactor	2
D1	9095.10.110	Manual Snap Wrench	1
	9013.10.950	Sterilizable Box	1

SMR PRIMARY SURGICAL TECHNIQUE

Instrument set

▼ 9013.20.000 'Endoprosthesis' Instrument Set for SMR Shoulder Prosthesis

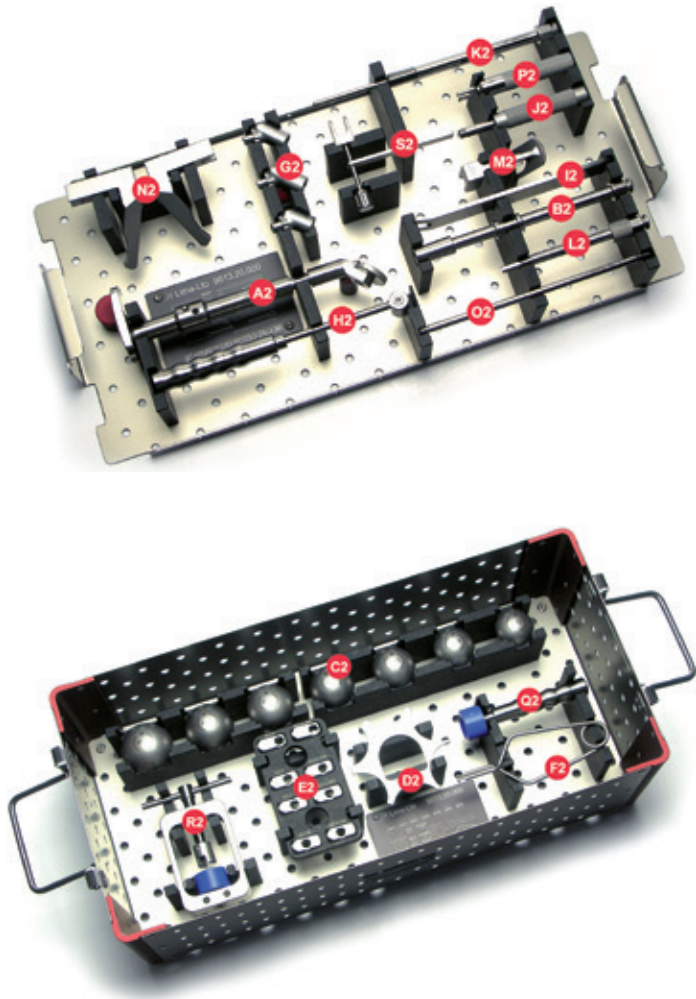

Ref.	CODE	DESCRIPTION	Qt.
A2	9013.02.320	Prosthesis Introducer	1
B2	9013.02.400	Wrench for Knurled Stems	1
C2	9013.22.420	Trial Humeral Head Dia. 42 mm	1
C2	9013.22.440	Trial Humeral Head Dia. 44 mm	1
C2	9013.22.460	Trial Humeral Head Dia. 46 mm	1
C2	9013.22.480	Trial Humeral Head Dia. 48 mm	1
C2	9013.22.500	Trial Humeral Head Dia. 50 mm	1
C2	9013.22.520	Trial Humeral Head Dia. 52 mm	1
C2	9013.22.540	Trial Humeral Head Dia. 54 mm	1
D2	9013.22.750	Head Gauge	1
E2	9013.30.010	Trial Neutral Adaptor STD	1
E2	9013.30.015	Trial Ecc. 2 mm Adaptor STD	1
E2	9013.30.020	Trial Ecc. 4 mm Adaptor STD	1
E2	9013.30.030	Trial Ecc. 8 mm Adaptor STD	1
E2	9013.31.010	Trial Neutral Adaptor Long	1
E2	9013.31.015	Trial Ecc. 2 mm Adaptor Long	1
E2	9013.31.020	Trial Ecc. 4 mm Adaptor Long	1
E2	9013.31.030	Trial Ecc. 8 mm Adaptor Long	1
F2	9013.30.100	Pliers for Trial Adaptor	1
G2	9013.50.010	Trial Humeral Body Medium	1
G2	9013.50.020	Trial Humeral Body Long	1
G2	9013.50.030	Trial Humeral Body Short	1
H2	9013.50.100	Body Stopper	1
I2	9013.50.120	Head Extractor	1
J2	9013.50.160	Extractor for Humeral Body	1
K2	9013.50.170	Universal Stem for Extractor	1
L2	9013.50.200	Allen Wrench	1
M2	9013.50.250	45° Stop Guide	1
N2	9013.50.300	Right Resection Mask	1
N2	9013.50.310	Left Resection Mask	1
O2	9013.50.315	Alignment Rod	1
P2	9013.52.160	Expansion Extractor	1
Q2	9075.10.120	Humeral Head Impactor	1
R2	9075.10.135	Humeral Head Press	1
S2	9075.10.800	Centimeter	1
	9013.20.950	Sterilizable Box	1

SMR PRIMARY SURGICAL TECHNIQUE

Instrument set

▼ 9013.30.000 'Glenoid' Instrument Set for SMR Shoulder Prosthesis

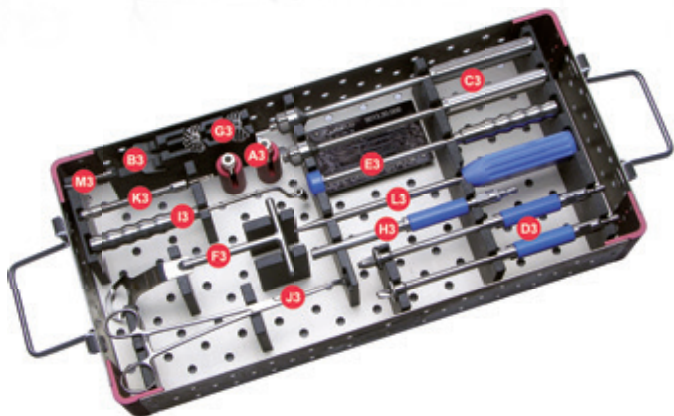

Ref.	CODE	DESCRIPTION	Qt.
A3	9013.02.305	Extractor for SMALL-R M-B Glenoid	1
A3	9013.02.310	Extractor for M-B Glenoid	1
B3	9013.50.150	Humeral Cover	1
C3	9013.75.100	SMALL-R M-B Glenoid Impactor	1
C3	9013.75.110	SMALL/STD/LARGE M-B Glenoid Impactor	1
D3	9013.75.115	SMALL-R Glenoid Drill	1
D3	9013.75.120	Glenoid Drill	1
E3	9075.10.140	Cemented Glenoid Impactor	1
F3	9075.10.280	Fukuda Retractor	1
G3	9075.10.300	Glenoid Reamer - SMALL	1
G3	9075.10.310	Glenoid Reamer - STD	1
H3	9075.10.350	Glenoid Reamers Shaft	1
I3	9075.10.400	Drill Guide	1
J3	9095.10.115	Pliers for Screws	1
K3	9095.10.180	Flexible Mandrel	1
L3	9095.10.222	Screwdriver	1
M3	9095.10.249	Helix Drill - Dia. 3.5 x 50mm	1
	9013.30.950	Sterilizable Box	1

SMR PRIMARY SURGICAL TECHNIQUE

Instrument set

▼ 9013.40.000 'Reverse' Instrument Set for SMR Shoulder Prosthesis

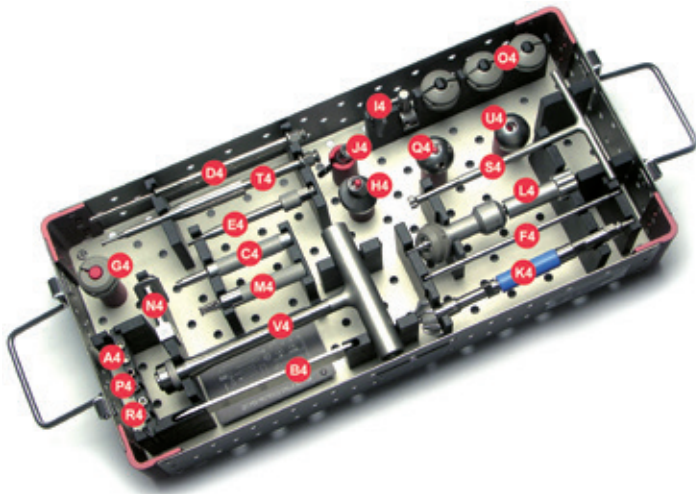

Ref.	CODE	DESCRIPTION	Qt.
A4	1350.15.001	Screw for Humeral Body	2
B4	9013.50.120	Head Extractor	1
C4	9013.50.160	Extractor for Humeral Body	1
D4	9013.50.170	Universal Stem for Extractor	1
E4	9013.50.200	Allen Wrench	1
F4	9013.50.315	Alignment Rod	1
G4	9013.52.001	Trial Extension for Humeral Reverse Body	1
H4	9013.52.010	Trial Reverse Humeral Body	1
I4	9013.52.100	Resection Mask for Reverse Prosth.	1
J4	9013.52.115	Guide for Conical Reamer	1
K4	9013.52.130	Conical Reamer	1
L4	9013.52.140	Humeral Body Impactor	1
M4	9013.52.160	Expansion Extractor	1
N4	9013.52.200	30° Stop Guide	1
O4	9013.60.010	STD Trial Liner	1
O4	9013.60.015	+3 Trial Liner	1
O4	9013.60.030	+6 Trial Liner	1
P4	9013.74.105	Guide Screw SMALL-R Trial Glenosphere	2
Q4	9013.74.110	Trial Glenosphere Dia. 36mm	1
R4	9013.74.120	Guide-Screw for Trial Glenosphere	2
S4	9013.74.130	T Driver for Trial Glenosphere	1
T4	9013.74.140	Glenosphere Impactor-Extractor	1
U4	9013.76.030	Trial Ecc. Glenosphere Dia. 36mm	1
V4	9095.10.110	Manual Snap Wrench	1
	9013.40.950	Sterilizable Box	1

SMR PRIMARY SURGICAL TECHNIQUE

Instrument set

▼ 9013.42.000 SMR Reverse HP

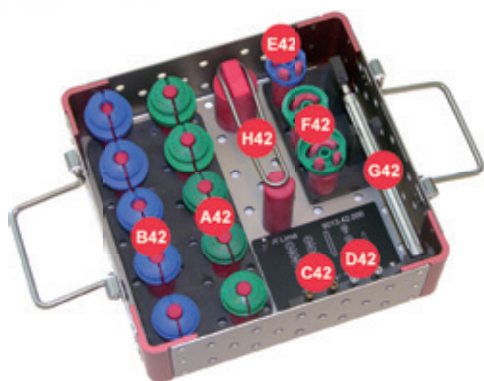

Ref.	CODE	DESCRIPTION	Qt.
A42	9013.62.010	Trial Liner SHORT Dia. 44mm	1
A42	9013.62.015	Trial Liner MEDIUM Dia. 44mm	1
A42	9013.62.020	Trial Liner LONG Dia. 44mm	1
A42	9013.62.115	Trial Liner Lateralizing MEDIUM Dia. 44mm	1
A42	9013.62.120	Trial Liner Lateralizing LONG Dia. 44mm	1
B42	9013.65.010	Trial Liner SHORT Dia. 40mm	1
B42	9013.65.015	Trial Liner MEDIUM Dia. 40mm	1
B42	9013.65.020	Trial Liner LONG Dia. 40mm	1
B42	9013.65.115	Trial Liner Lateralizing MEDIUM Dia. 40mm	1
B42	9013.65.120	Trial Liner Lateralizing LONG Dia. 40mm	1
C42	9013.74.105	Guide-Screw SMALL-R Trial Glenosphere	2
D42	9013.74.120	Guide-Screw Trial Glenosphere	2
E42	9013.74.401	Trial Glenosphere Dia. 40mm	1
F42	9013.74.440	Trial Glenosphere Dia. 44mm	1
F42	9013.74.444	Trial Glenosphere Dia. 44mm Corrective	1
G42	9013.74.605	Positioner for Glenosphere Plug	1
H42	9013.74.650	Trial Glenosphere Positioner	1
	9013.42.950	Sterilizable Box	1

SMR PRIMARY SURGICAL TECHNIQUE

Instrument set

▼ 9013.90.000 'CTA' Instrument Set for SMR Shoulder Prosthesis

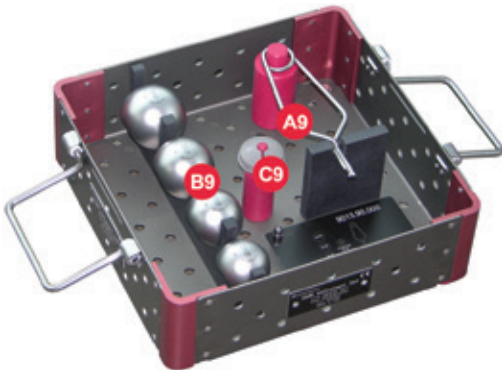

Ref.	CODE	DESCRIPTION	Qt.
A9	9013.30.100	Pliers for Trial Adaptor	1
B9	9013.23.420	Trial CTA Head Dia. 42mm	1
B9	9013.23.460	Trial CTA Head Dia. 46mm	1
B9	9013.23.500	Trial CTA Head Dia. 50mm	1
B9	9013.23.540	Trial CTA Head Dia. 54mm	1
C9	9013.23.600	Trial Adaptor Dia. 36mm	1
	9013.90.950	Sterilizable Box	1

▼ 9013.62.200 SMR Ceramic Liner Impactor



Ref.	CODE	DESCRIPTION	Qt.
	9013.62.200	SMR Ceramic Liner Impactor	1

SMR PRIMARY SURGICAL TECHNIQUE

Product Codes



▼ FINNED HUMERAL BODY WITH LOCKING SCREW

Ti6Al4V	1350.15.110	Finned Humeral Body
---------	-------------	---------------------



▼ TRAUMA HUMERAL BODIES WITH LOCKING SCREW

Ti6Al4V	1350.15.010	Medium
	1350.15.020	Long
	1350.15.030	Short



▼ CEMENTED STEMS L. 80 MM

Ti6Al4V	1306.15.120	Dia. 12 mm
	1306.15.140	Dia. 14 mm
	1306.15.160	Dia. 16 mm
	1306.15.180	Dia. 18 mm
	1306.15.200	Dia. 20 mm



▼ CEMENTLESS MINI STEMS L. 60 MM

Ti6Al4V	1304.15.110	Dia. 11 mm	■
	1304.15.120	Dia. 12 mm	■
	1304.15.130	Dia. 13 mm	■



▼ CEMENTLESS FINNED STEMS L. 80 MM

Ti6Al4V	1304.15.140	Dia. 14 mm
	1304.15.150	Dia. 15 mm
	1304.15.160	Dia. 16 mm
	1304.15.170	Dia. 17 mm
	1304.15.180	Dia. 18 mm
	1304.15.190	Dia. 19 mm
	1304.15.200	Dia. 20 mm
	1304.15.210	Dia. 21 mm
	1304.15.220	Dia. 22 mm
	1304.15.230	Dia. 23 mm
	1304.15.240	Dia. 24 mm

■ Upon Request

SMR PRIMARY SURGICAL TECHNIQUE

Product Codes



▼ LARGE RESECTION STEMS

Ti6Al4V	1313.15.010	Dia. 7 mm, h 50 mm
	1313.15.040	Dia. 7 mm, h 80 mm
	1313.15.110	Dia. 10 mm, h 50 mm
	1313.15.140	Dia. 10 mm, h 80 mm



▼ MODULAR AUGMENTS

Ti6Al4V	1314.15.020	h 20 mm
	1314.15.030	h 30 mm
	1314.15.040	h 40 mm
	1314.15.050	h 50 mm



▼ RING

Ti6Al4V	1314.15.200	Ring
---------	-------------	------



▼ CEMENTED REVISION STEMS

Ti6Al4V	1309.15.134	Dia. 13 mm - h 150 mm	
	1309.15.136	Dia. 13 mm - h 180 mm	
	1309.15.138	Dia. 13 mm - h 210 mm	■
	1309.15.154	Dia. 15 mm - h 150 mm	
	1309.15.156	Dia. 15 mm - h 180 mm	
	1309.15.158	Dia. 15 mm - h 210 mm	■

■ Upon Request

SMR PRIMARY SURGICAL TECHNIQUE

Product Codes

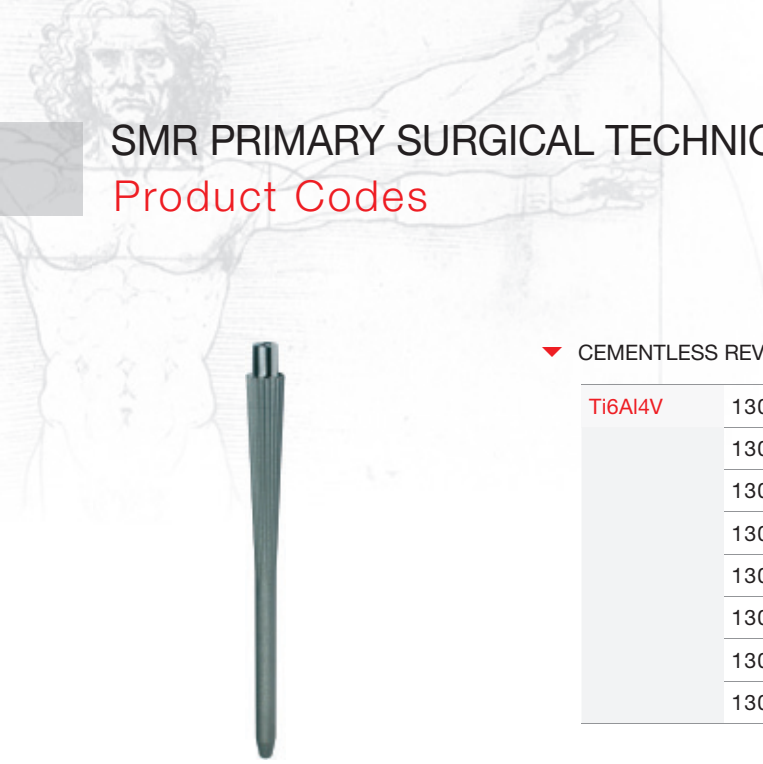

▼ CEMENTLESS REVISION STEMS

Ti6Al4V	1308.15.134	Dia. 13 mm - h 150 mm
	1308.15.136	Dia. 13 mm - h 180 mm
	1308.15.144	Dia. 14 mm - h 150 mm
	1308.15.146	Dia. 14 mm - h 180 mm
	1308.15.154	Dia. 15 mm - h 150 mm
	1308.15.156	Dia. 15 mm - h 180 mm
	1308.15.164	Dia. 16 mm - h 150 mm
	1308.15.166	Dia. 16 mm - h 180 mm



▼ NEUTRAL ADAPTOR TAPERS

Ti6Al4V	1330.15.270	0 mm, Standard
	1331.15.270	0 mm, Long



▼ ECCENTRIC ADAPTOR TAPERS

Ti6Al4V		STANDARD
	1330.15.272	+ 2 mm
	1330.15.274	+ 4 mm
	1330.15.278	+ 8 mm
		LONG
	1331.15.272	+ 2 mm
	1331.15.274	+ 4 mm
	1331.15.278	+ 8 mm



▼ HUMERAL HEADS

CoCrMo	1322.09.400	Dia. 40 mm	■
	1322.09.420	Dia. 42 mm	
	1322.09.440	Dia. 44 mm	
	1322.09.460	Dia. 46 mm	
	1322.09.480	Dia. 48 mm	
	1322.09.500	Dia. 50 mm	
	1322.09.520	Dia. 52 mm	
	1322.09.540	Dia. 54 mm	

■ Upon Request

SMR PRIMARY SURGICAL TECHNIQUE

Product Codes



▼ HUMERAL HEADS

Ti6Al4V	1322.15.420	Dia. 42 mm	■
	1322.15.440	Dia. 44 mm	■
	1322.15.460	Dia. 46 mm	■
	1322.15.480	Dia. 48 mm	■
	1322.15.500	Dia. 50 mm	■
	1322.15.520	Dia. 52 mm	■
	1322.15.540	Dia. 54 mm	■



▼ CTA HUMERAL HEADS

CoCrMo	1323.09.420	Dia. 42 mm	
	1323.09.460	Dia. 46 mm	
	1323.09.500	Dia. 50 mm	
	1323.09.540	Dia. 54 mm	



▼ CTA HEADS ADAPTOR FOR REVERSE HUMERAL BODY

Ti6Al4V	1352.15.200	Adaptor 36 mm for Reverse Humeral Body	■
---------	-------------	--	---



▼ REVERSE HUMERAL BODIES WITH LOCKING SCREW

Ti6Al4V	1352.20.010	HA Coated Reverse Humeral Body	
	1352.15.005	Short Reverse Humeral Body only for inversion	■
	1352.15.050	Finned Reverse Humeral Body for Trauma	■
	1352.15.001	Humeral Extension +9 mm	

■ Upon Request

SMR PRIMARY SURGICAL TECHNIQUE

Product Codes



▼ REVERSE LINERS 36 MM

UHMWPE X-LIMA	1360.50.010	Standard	
	1360.50.015	+3 mm	
	1360.50.020	+6 mm	
	1361.50.010	Retentive Std.	■
	1361.50.015	Retentive +3 mm	■
	1361.50.020	Retentive +6 mm	■



▼ GLENOSPHERE 36 MM WITH CONNECTOR

CoCrMo	1374.09.105	Glenosphere - Small-R	
	1374.09.110	Glenosphere	
	1376.09.025	Eccentric Glenosphere - Small-R	
	1376.09.030	Eccentric Glenosphere	



▼ GLENOSPHERE 36 MM WITH CONNECTOR

Ti6Al4V	1374.15.105	Glenosphere - Small-R	■
	1374.15.110	Glenosphere	■
	1376.15.025	Eccentric Glenosphere - Small-R	■
	1376.15.030	Eccentric Glenosphere	■

■ Upon Request

SMR PRIMARY SURGICAL TECHNIQUE

Product Codes

▼ REVERSE HP LINERS



CoCrMo		40 MM	
	1365.09.010	Short	
	1365.09.015	Medium	
	1365.09.020	Long	
	1365.09.115	Lateralizing Liner - Medium	■
	1365.09.120	Lateralizing Liner - Long	■
		44 MM	
	1362.09.010	Short	
	1362.09.015	Medium	
	1362.09.020	Long	
	1362.09.115	Lateralizing Liner - Medium	■
	1362.09.120	Lateralizing Liner - Long	■

▼ REVERSE CERAMIC LINERS 44 MM



Alumina			
	1362.39.015	Medium	■
	1362.39.020	Long	■

▼ REVERSE HP GLENOSPHERE



UHMWPE X-LIMA + Ti6Al4V		40 MM	
	1374.50.400	Glenosphere	
		44 MM	
	1374.50.440	Glenosphere	
	1374.50.444	Corrective Glenosphere	

▼ CONNECTORS WITH SCREW *



Ti6Al4V			
	1374.15.305	Small-R	
	1374.15.310	Small STD	

* Necessary with REVERSE HP, optional with 36 mm glenospheres

■ Upon Request

SMR PRIMARY SURGICAL TECHNIQUE

Product Codes



▼ CEMENTED GLENOID

UHMWPE	1378.50.005	Small-R
	1378.50.010	Standard
	1378.50.020	Small



▼ CEMENTED GLENOID 3 PEGS

UHMWPE	1379.51.010	Standard
X-LIMA	1379.51.020	Small



▼ METAL BACK GLENOIDS L1

Ti6Al4V + PoroTi + HA	1375.20.005	Small - R
	1375.20.020	Small
	1375.20.010	Standard
	1375.20.030	Large



▼ LINERS FOR METAL BACK GLENOID L1

UHMWPE	1377.50.005	Small - R
	1377.50.020	Small
	1377.50.010	Standard
	1377.50.030	Large

■ Upon Request

SMR PRIMARY SURGICAL TECHNIQUE

Product Codes



▼ BONE SCREWS

Ti6Al4V		DIA. 6.5 MM
	8420.15.010	L. 20 mm
	8420.15.020	L. 25 mm
	8420.15.030	L. 30 mm
	8420.15.040	L. 35 mm
	8420.15.050	L. 40 mm



▼ GLENOID PLATES *

Ti CP		
	1374.15.505	Small-R - Double
	1374.15.510	Small STD - Double

* Glenoid Plates are suitable only for REVERSE HP



▼ CORTICAL BONE SCREWS

Ti6Al4V		DIA. 4.5 MM
	8430.15.010	L. 32 mm
	8430.15.020	L. 36 mm
	8430.15.030	L. 40 mm
	8430.15.040	L. 44 mm
	8430.15.050	L. 48 mm
	8430.15.060	L. 52 mm

This surgical technique is provided for purely illustrative reasons. The surgeon must always proceed on the basis of his personal experience and considering the conditions of each individual patient.

For further information about our products, please visit our web site at **www.limacorporate.com**

Limacorporate spa
Via Nazionale, 52
33038 Villanova di San Daniele
Udine - Italy
Tel.: +39 0432 945511
Fax: +39 0432 945512
E-mail: info@limacorporate.com
www.limacorporate.com

Lima Implantés slú
C/ Lluça 28, 2º
08028 Barcelona - Spain
Tel.: +34 93 228 9240
Fax: +34 93 426 1603
E-mail: lima@limaimplantés.com

Lima France sas
Les Espaces de la Sainte Baume
Parc d'Activité de Gemenos - Bât.A5
30 Avenue du Château de Jouques
13420 Gemenos - France
Tel: +33 (0) 4 42 01 63 12
Fax: +33 (0) 4 42 04 17 25
E-mail: info@limafrance.com

Lima O.I. doo
Ante Kovacic, 3
10000 Zagreb - Croatia
Tel.: +385 (0) 1 2361 740
Fax: +385 (0) 1 2361 745
E-mail: lima-oi@lima-oi.hr

Lima Switzerland sa
Birkenstrasse, 49
CH-6343 Rotkreuz - Zug
Switzerland
Tel: +41 (0) 41 747 06 60
Fax: +41 (0) 41 747 06 69
E-mail: info@lima-switzerland.ch

Lima Japan kk
Shinjuku Center Building, 29th floor
1-25-1, Nishi-shinjuku, Shinjuku,
Tokyo 163-0629 - Japan
Tel.: +81 3 5322 1115
Fax: +81 3 5322 1175

Lima CZ sro
Do Zahrádek I., 157/5
155 21 Praha 5 – Zličín –
Czech Republic
Tel.: +420 222 720 011
Fax: +420 222 723 568
E-mail: info@limacz.cz

Lima Deutschland GmbH
Kapstadtring 10
22297 Hamburg - Germany
Tel.: +49 40 6378 4640
Fax: +49 40 6378 4649
E-mail: info@lima-deutschland.com

Lima Austria GmbH
Ignaz-Köck-Strasse 10 / Top 3.2
1210 Wien - Austria
Tel.: +43 (1) 2712 469
Fax: +43 (1) 2712 469 100
E-mail: info@lima-austria.at

Lima SK s.r.o.
Zvolenská cesta 14
97405 Banská Bystrica - Slovakia
Tel.: +421 484 161 133
Fax: +421 484 161 138
E-mail: info@lima-sk.sk

Lima Netherlands
Havenstraat 30
3115 HD Schiedam
The Netherlands
Tel: +31 (0) 10 246 26 60
Fax: +31 (0) 10 246 26 61
info@limanederland.nl
www.limanederland.nl

Lima Implantes Portugal S.U. Lda
Rua Olavo D'Eça Leal N°6 Loja-1
1600-306 Lisboa - Portugal
Tel : +35 121 727 233 7

Lima Orthopaedics Australia Pty Ltd
Unit 1, 40 Ricketts Rd
Mt Waverley 3149
Victoria Australia
Tel.: +61 (03) 9550 0200
Fax: +61 (03) 9543 4003
www.limaortho.com.au

Lima Orthopaedics New Zealand Ltd
Zone 23, Unit 102, Edwin Street, Mt Eden
Auckland 1024
New Zealand
Tel.: +64 (09) 531 5522
Fax: +64 (09) 522 3380

Lima Orthopaedics UK Limited
The Pavillon, Campus 5, Unit 1
Third Avenue
Letchworth Garden City
Hertfordshire SG6 2JF
United Kingdom
Tel.: +44 08 45833 4435
Fax: +44 08 45833 4436

Lima USA Inc.
2106 W. Pioneer Parkway, Suite 126
Arlington, TX 76013
Tel.: +1 817-342-0240 / 800-962-2578
Fax: +1 817-342-0241 / 800-962-2579

Lima Orthopaedics Sweden AB
Företagsallén 14 B
SE-184 40 ÅKERSBERGA
Sweden
Tel.: +46 8 544 103 87
Fax.: +46 8 540 862 68
www.links sweden.se

Hit Medica spa
Strada Borrana 38
47899 Serravalle, Republic of San Marino
Tel.: +378 0549 961911
Fax: +378 0549 961912
E-mail: info@hitmedica.com

The people appearing in the photographs on this publication are models and used for illustrative purposes only.

This publication is not intended for distribution in the U.S.

www.limacorporate.com

B.1304.23.001.1

101200

