

LFIT™ Anatomic

CoCr Femoral Heads with **X3™** Liners



- Decreasing Dislocation
- Increasing ROM

**Restoration
Modular™**
Femoral Hip Stem

Dislocation

Decreasing Risk of Dislocation

Prevention of dislocation after total hip arthroplasty can be critical in minimising patient morbidity. Recommendations to decrease the prevalence of dislocations include, but are not limited to, implant design, component positioning and surgical approach. LFIT™ Anatomic CoCr Femoral Heads provide surgeons with a solution to help minimise dislocation.

Increase Jump Distance, Decrease Dislocation

The relationship between jump distance and the risk of dislocation is inversely proportional. As jump distance increases, the risk of dislocation theoretically decreases. Jump distance is defined as the vertical distance the femoral head must travel to dislocate after impingement.

Jump distance is clinically relevant when it more closely mimics the natural anatomy and is measured at 45°.

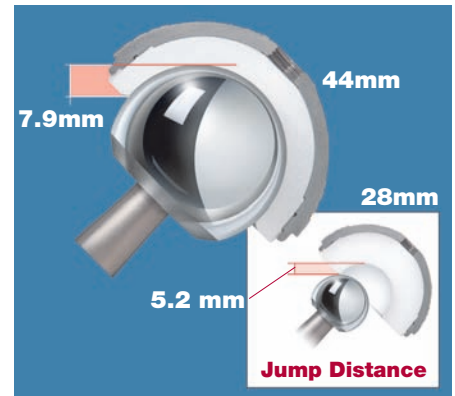

X3™ Liners

Catalog No.	Size	Trident® PSL® HA Shell Size (mm)	Trident® Hemispherical Shell Size (mm)
623-00-36D	36D	46, 48	48, 50
623-00-40E	40E	50, 52	52, 54
623-00-40F	40F	54, 56	56, 58
623-00-40G	40G	58, 60	60, 62
623-00-40H	40H	62, 64	64, 66
623-00-40I	40I	66, 68	68, 70
623-00-40J	40J	70, 72	72, 74
623-00-44F	44F	54, 56	56, 58
623-00-44G	44G	58, 60	60, 62
623-00-44H	44H	62, 64	64, 66
623-00-44I	44I	66, 68	68, 70
623-00-44J	44J	70,72	72, 74

V40™ Taper LFIT™ Anatomic Heads

Catalog No.	Diameter (mm)	Offset (mm)
6260-9-036	36	-5
6260-9-136	36	+0
6260-9-236	36	+5
6260-9-336	36	+10
6260-9-040	40	-4
6260-9-140	40	+0
6260-9-240	40	+4
6260-9-340	40	+8
6260-9-440	40	+12
6260-9-044	44	-4
6260-9-144	44	+0
6260-9-244	44	+4

Wear

Testing results showed lower wear rates with LFIT™ Anatomic CoCr Femoral Heads on X3™ when compared with the wear rates of LFIT™ Anatomic CoCr Femoral Heads on conventional (N2/Vac™) polyethylene.

The reduction in wear rates with the X3™ material allows the potential use of larger size femoral heads without affecting the polyethylene performance. Please contact your local representative for further information.



LFIT™ Anatomic CoCr Femoral Heads

This document is intended solely for the use of healthcare professionals.

The information presented in this brochure is intended to demonstrate the breadth of Stryker product offerings. Always refer to the package insert, product label and/or user instructions before using any Stryker product. Products may not be available in all markets. Product availability is subject to the regulatory or medical practices that govern individual markets. Please contact your Stryker representative if you have questions about the availability of Stryker products in your area.

Products referenced with ™ designation are trademarks of Stryker.

Products referenced with ® designation are registered trademarks of Stryker.

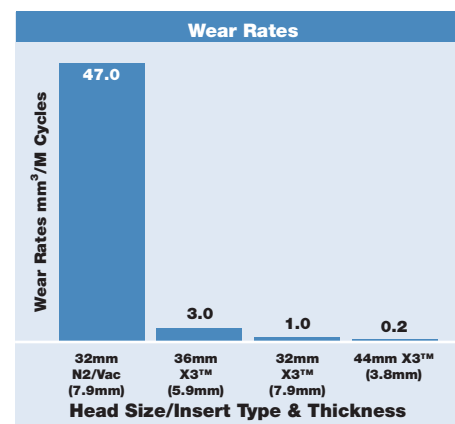

Stryker Orthopaedics Technical Report: RD-06-021 Rev. 1.



Literature Number: MTXLFITSSEN03

MTX/GS 03/07

Copyright © 2007 Stryker

Stryker SA
Cité-Centre
Grand-Rue 90
1820 Montreux
Switzerland
t: +41 21 966 12 01
f: +41 21 966 12 00
www.europe.stryker.com